



RTRE 3 SPEED CONTROL

Item no. 5009

Document type: **Product card**

Document date: **2019-06-24**

Generated by: **Systemair Online Catalogue**

Description

Manual five-step transformer (with motor protection)

A single-phase transformer which controls the fan speed by altering the supply voltage in five fixed steps. The steps are adjusted manually, using the control knob on the front of the unit. An integral motor protection device is included which cuts the supply voltage to the fan if the thermal contact in the fan motor is activated. The unit is reset by turning the knob to "0" for 10 seconds, after which the unit restarts.

The unit has input terminals for room thermostat RT, which stops the supply voltage to the fan when the circuit is broken. These terminals are linked before delivery. The transformer has 230V terminals for operating dampers, electric water-heater batteries or other external equipment. These terminals have no current when the transformer knob is in position 0, or when the TK or RT input is open. The indicator lamp on the front shows when the transformer is in operation. The fuse may be reset from outside. The RTRE has a self-extinguishing thermoplastic casing. Supply voltage: 230V 50/60Hz.



Technical parameters

Voltage	230	V
Phase	1	~
Frequency	50/60	Hz
Current	3	A
Enclosure class	54	
Width	105	mm
Depth	106	mm
Height	203	mm
Weight	2,6	kg

Get In Touch

Call: [0845 6880112](tel:08456880112)
 Email: info@adremit.co.uk

Our Address

Puravent, Adremit Limited, Unit 5a, Commercial Yard,
 Settle, North Yorkshire, BD24 9RH

Dimensions

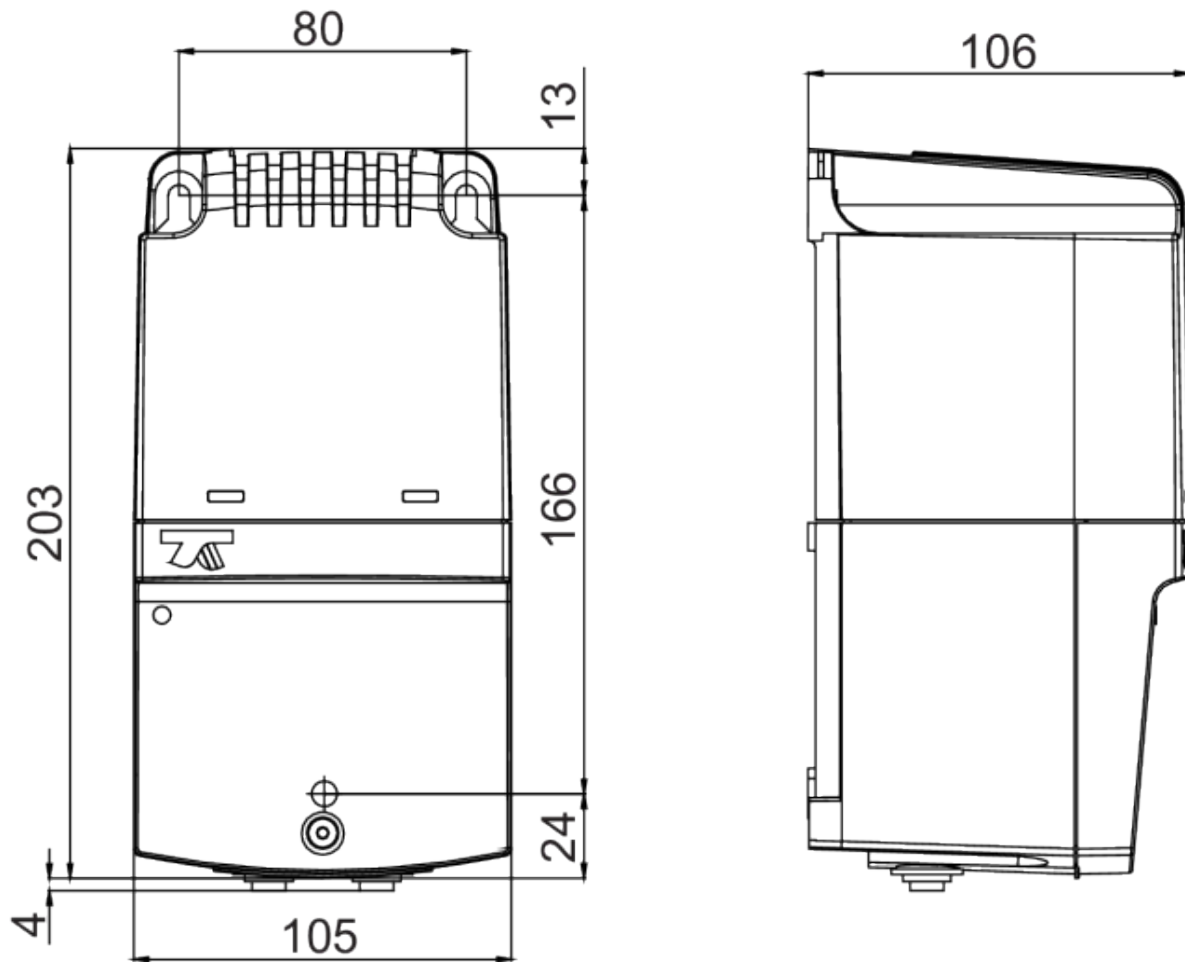

Documentation

 RE RTRE REU_ IMO_ GB.pdf (245,21kB)

 Declaration Of Conformity_RE_REU_RTRE_EN-2017.pdf (26,64kB)

Wiring

RTRE 1,5 RTRE 3 RTRE 5

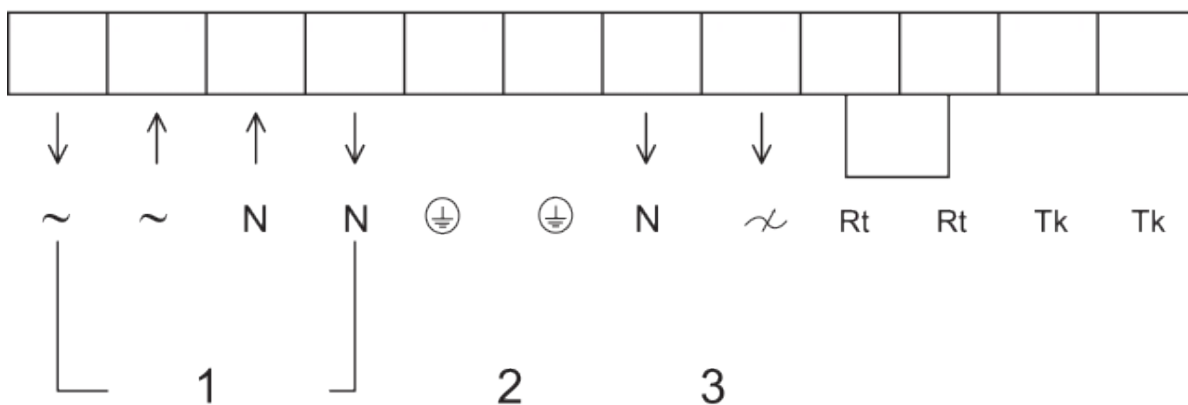

Get In Touch

 **Call:** [0845 6880112](tel:08456880112)
 **Email:** info@adremit.co.uk

Our Address

Puravent, Adremit Limited, Unit 5a, Commercial Yard,
 Settle, North Yorkshire, BD24 9RH

- 
- 1. = Relay connection
 - 2. = Earth
 - 3. = Fan
- Rt. = Thermostat
Tk. = Motor protection

Get In Touch



Call: [0845 6880112](tel:08456880112)



Email: info@adremit.co.uk

Our Address

Puravent, Adremit Limited, Unit 5a, Commercial Yard,
Settle, North Yorkshire, BD24 9RH