

# F251-16-50 COOKERHOOD TRANSF

Item no. 5930

Document type: **Product card**  
 Document date: **2019-08-01**  
 Generated by: **Systemair Online Catalogue**

## Description

- Provides good lighting
- Easy to clean
- Available in 3 widths

The Systemair kitchen extract hood provides an elegant and easily adaptable ventilation system for your kitchen. The high capacity hood has a rigid area with a front screen of hardened sheet glass. The hood provides excellent light for kitchen work and is fitted with a wire mesh filter that is easy to clean. This filter should be cleaned at least once a month, either by hand or in the dishwasher. Simple connections with our flexible ducting.



The F 251-16 hood is fitted with a transformer with a three-speed fan control, grease filter, light and damper. The hood is supplied with an already-fitted quick-coupling device for installation with the kitchen shelf fans.

The versions -50, -60 and -70 indicates the width of the hood.

-60 is available in stainless steel finish.

## Technical parameters

Other		
Weight	7,7	kg
Default group		
Voltage	230	V
Frequency	50	Hz
Phase	1	~
Input power (P1)	300	W
Material in filter	Knitted alu. carpet	

Dimensions

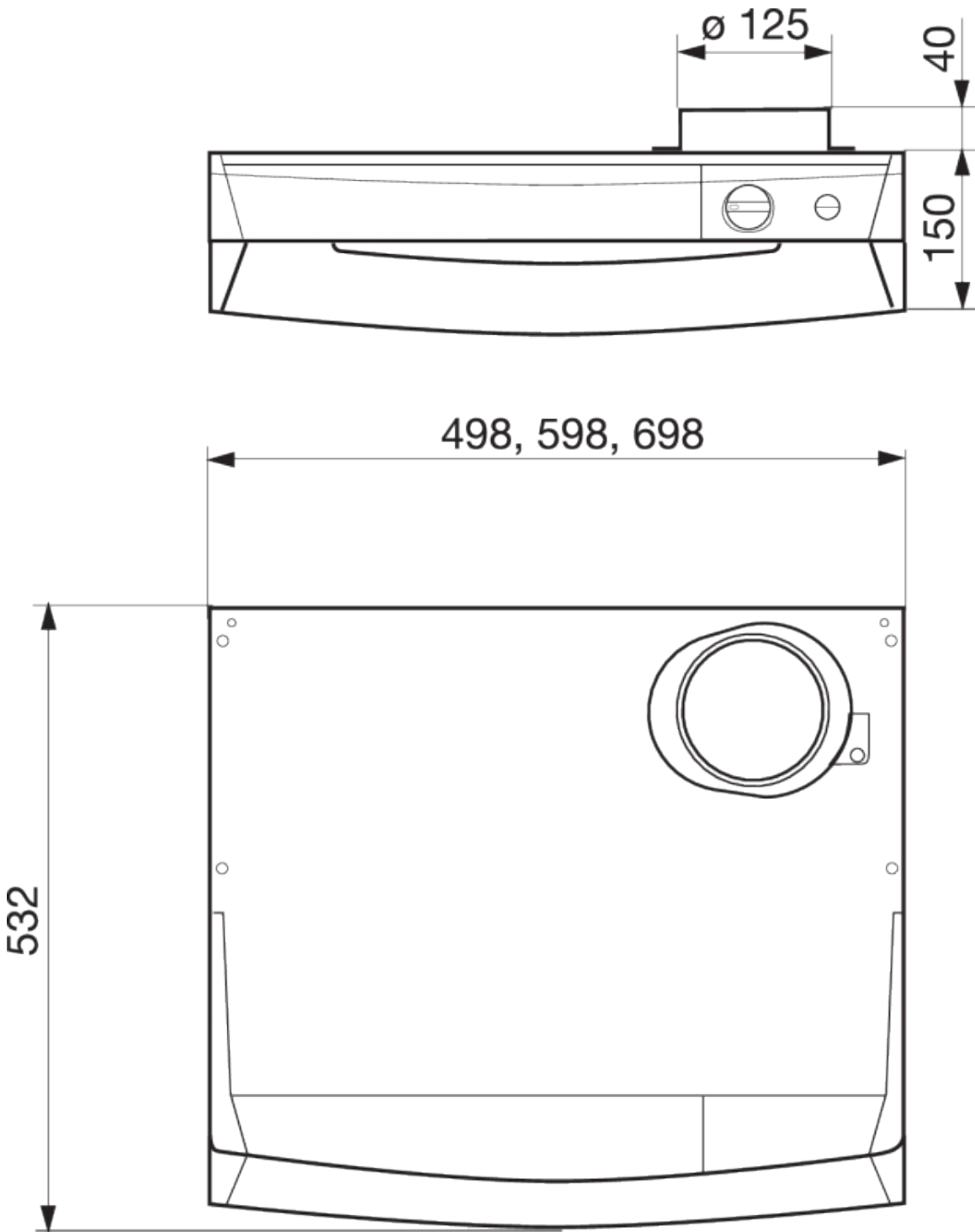

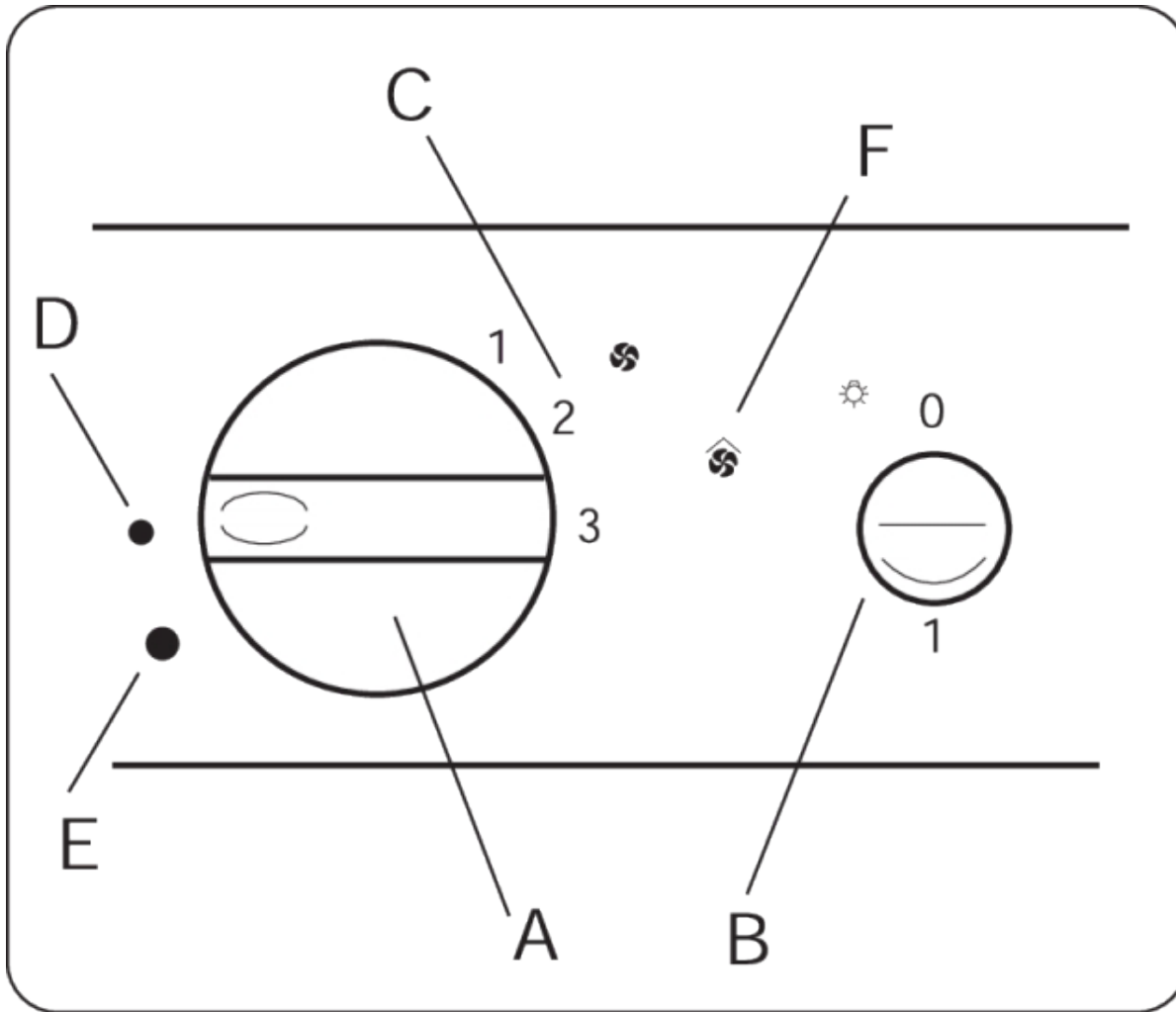

- A Handle for fan motor/damper
- B Button for lighting
- C Fan speed, three steps
- D General house ventilation, low speed
- E General house ventilation, force speed
- F Indicator lamp for general house ventilation, force speed

## Accessories

## Documentation

 F 251-16 WD.pdf (1,96MB)

 F 251-16 IMO 122648.pdf (312,11kB)

## Diagram

Setting Forced flow

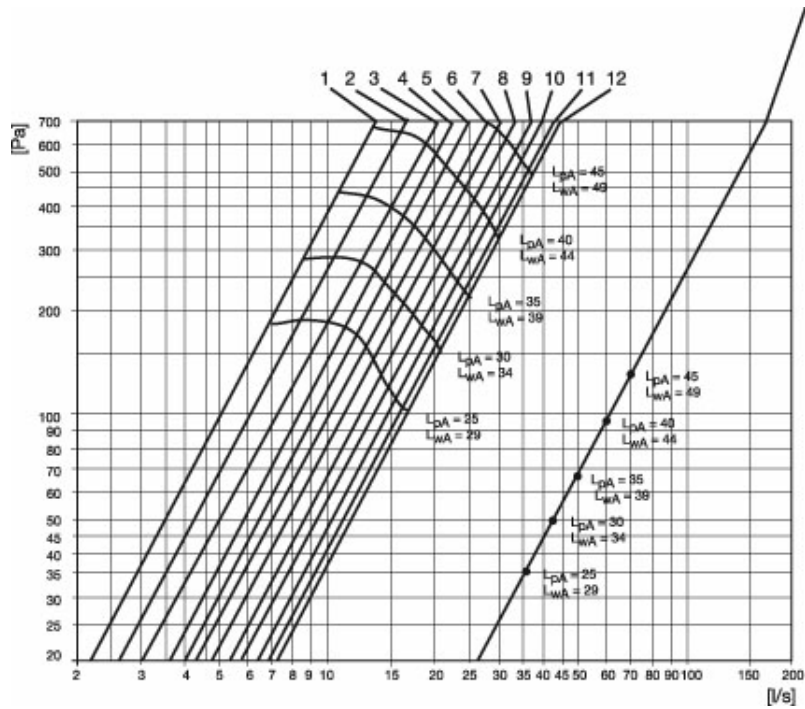

## Specification text