

KBR 355D2 IE3 THERMO FAN

Item no. 87918

Document type: **Product card**
 Document date: **2019-07-16**
 Generated by: **Systemair Online Catalogue**

Description

- Max temperature of transported air 120°C
- Speed-controllable(exept models 280D2 & 280D2-4)
- Integral thermal contacts
- Low sound level

The KBR fans have impellers manufactured from aluminum with backward-curved blades and external rotor motors. The KBR casing is manufactured from doubleskinned galvanised sheet steel and is insulated with 50 mm mineral wool.

The KBR fans have a swing-out door for easy inspection and service. The direction of the door opening can easily be changed from left to right at site. The fan is isolated from the casing via connectors and anti-vibration dampers are incorporated into the base frame.

To protect the motors from overheating the KBR fans have integral thermal contacts(KBR 280D2 & 280D2-4 with PTC) with external leads for connection to a motor protection device.

Please note: Speed control by voltage, i.e. voltage transformers, is not possible!

In accordance with Commission Regulation (EC) no 640/2009 of the European Parliament - eco-design requirements for electric motors - the new international efficiency classes are binding as of 16 June 2011. These guidelines defined by CEMEP and EPACT are regarded as international standard for energy-saving high-efficiency motors for frequencies of 50 or 60 Hz and make the use of IE2 motors mandatory.

With this new and more efficient technology we offer our customers many advantages such as environmentally friendly operation, reduced energy consumption and hence lower emissions. IE3 motors have a higher efficiency even in part load operation and allow optimum adjustment to the operating point. In addition, the IE3 motors generate less noise and develop less heat, which has a positive influence on the efficiency and the cooling requirement of the motor. Please note: IE3 motors cannot be speed controlled by voltage, i.e. voltage transformers.



Technical parameters

Nominal data		
Voltage	400	V
Frequency	50	Hz
Phase	3	~
Input power (P1)	3556	W
Current	5,67	A
Max. airflow	2,02	m³/s
R.p.m.	2887	r.p.m.
Weight	81,4	kg
Temperature data		
Max. temperature of transported air	120	°C
Sound data		
Sound pressure level at 4 m	53	dB(A)
Sound pressure level at 10 m	45	dB(A)
Protection / Classification		
Insulation class	F	
Enclosure class, motor	IP55	

Diagrams

Diagrams

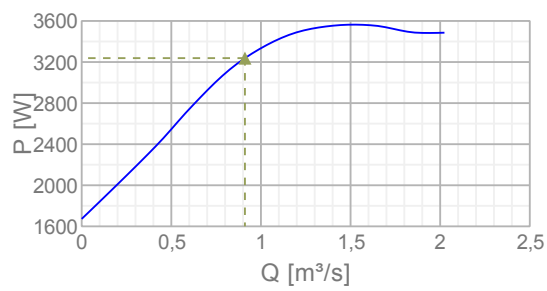
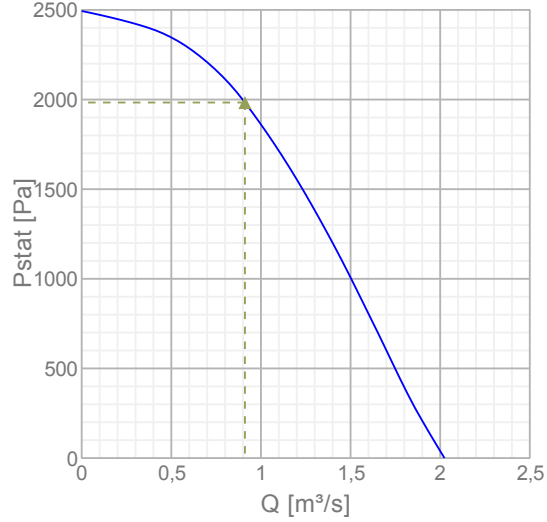

Max efficiency

Hydraulic data										
▲ Working air flow										0,911 m^3/s
▲ Working static pressure										1983 Pa
▲ Power										3238 W
Speed										2900 r.p.m.
Current										5,23 A
SFP										3,56 W/(l/s)
Voltage										400 V
Sound power level										
Inlet	dB(A)	63	125	250	500	1k	2k	4k	8k	Tot
Outlet	dB(A)	53	70	77	89	82	77	69	59	90

Dimensions

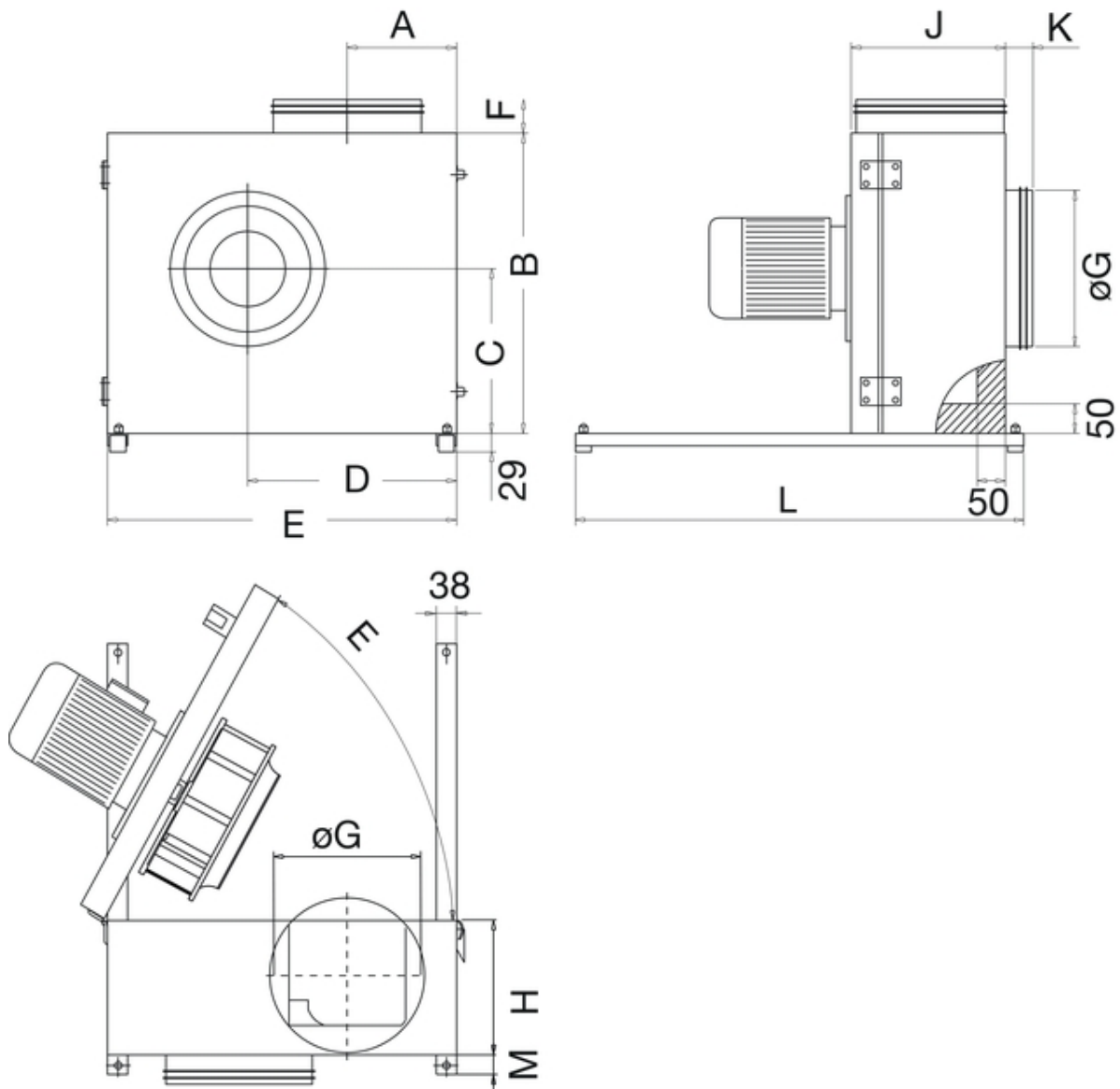

KBR	A	B	C	D	E	F	$\varnothing G$	H	J	K	L	M
355	206,7	655	372	451	770	125	355	273	331	70	770	55

Wiring

Dreiphasenmotor mit Kaltleiter Three phase motor with cold conductor Moteur triphasé avec résistance PTC

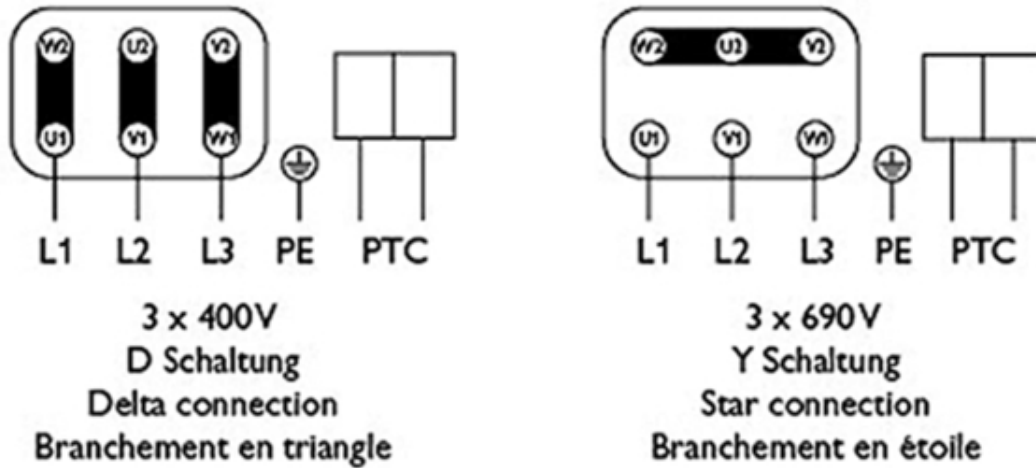

Drehrichtungsänderung durch Vertauschen von 2 Phasen
Changing of direction of rotation by interchanging of two phases
Changement de sens de rotation par inversion de deux phases

Typenschild beachten! See label! Voir plaque!

Accessories

Electric accessories

- [Trigger unit U-EK230E \(30199\)](#)
- [REV-5POL/05 ON/OFF \(33979\)](#)
- [REV-9POL/12 ON/OFF \(33981\)](#)
- [REV-5POL/05 incl. EMC KIT \(34549\)](#)
- [FRQ5S-10A+LED V2 \(36234\)](#)
- [FRQ5-10A+LED V2 \(36230\)](#)
- [FRQS-10A V2 \(36232\)](#)
- [FRQ-10A V2 \(36228\)](#)

Accessories

- [ASF 355/KB Flex. connection \(2719\)](#)
- [WBK 315/355 Wall bracket \(2721\)](#)
- [ALS-KBR drain plug \(2727\)](#)
- [WSD KBR-2 Weather roof f. motor \(2729\)](#)

Documentation

 [manual_kbr_en_\[003\].pdf \(3,41MB\)](#)

 [eu declaration of conformity_thermofans_en_\[002\].pdf \(46,39kB\)](#)

Specification text