

KD 250 L1 CIRC.DUCT FAN

Item no. 25334

Version: 50 Hz

Document type: **Product card**
 Document date: **2019-03-27**
 Generated by: **Systemair Online Catalogue**

Description

- High efficiency – low noise
- Speed-controllable
- Integral thermal contacts
- Can be installed in any position
- Maintenance-free and reliable

The KD series have external rotor motors with a new type of mixed flow impeller which reduces the external dimensions of the fans. These fans have a high capacity in relation to their compact design. Brackets are supplied with the fans to make installation easier. The FK mounting clamp facilitates easy installation and removal and prevents the transfer of vibrations to the duct. To protect the motor from overheating the fan has integral thermal contacts with electrical reset. The casing is manufactured from galvanised sheet steel.

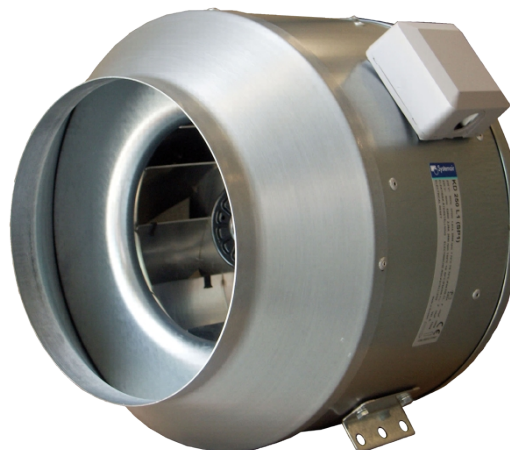

Technical parameters

Nominal data		
Voltage	230	V
Frequency	50	Hz
Phase	1	~
Input power (P1)	369	W
Current	1,6	A
Max. airflow	0,552	m³/s
R.p.m.	2604	r.p.m.
Capacitor	10	µF
Weight	9,4	kg
Temperature data		
Max. temperature of transported air	70	°C
Max. temperature of transported air when speed-controlled	70	°C
Sound data		
Sound pressure level at 3 m	54,5	dB(A)
Protection / Classification		
Insulation class	F	
Enclosure class, motor	IP44	

Diagrams

Diagrams

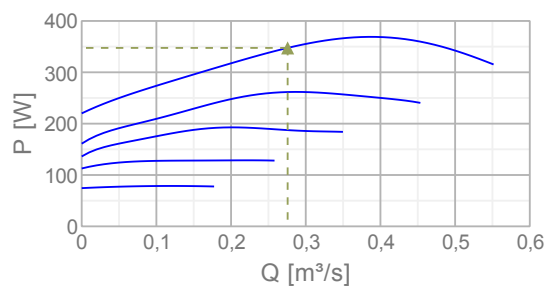
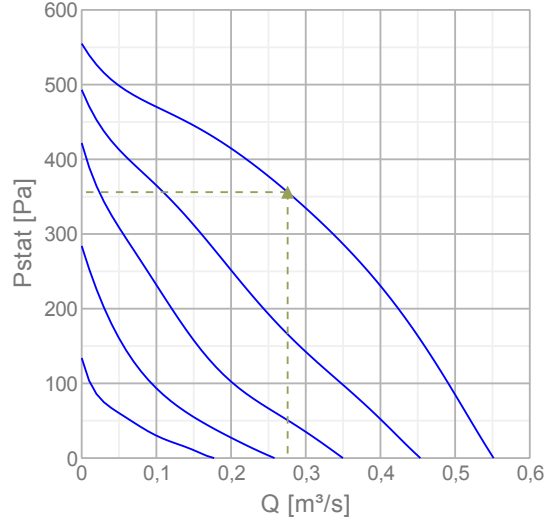

Max efficiency

Hydraulic data										
▲ Working air flow										0,276 m³/s
▲ Working static pressure										356 Pa
▲ Power										347 W
Speed										2637 r.p.m.
Current										1,51 A
SFP										1,26 W/(l/s)
Voltage										230 V
Sound power level		63	125	250	500	1k	2k	4k	8k	Tot
Inlet	dB(A)	56	73	75	78	75	71	71	65	82
Outlet	dB(A)	56	71	71	76	74	76	71	64	82
Surrounding	dB(A)	28	37	46	61	50	48	50	38	62

Dimensions

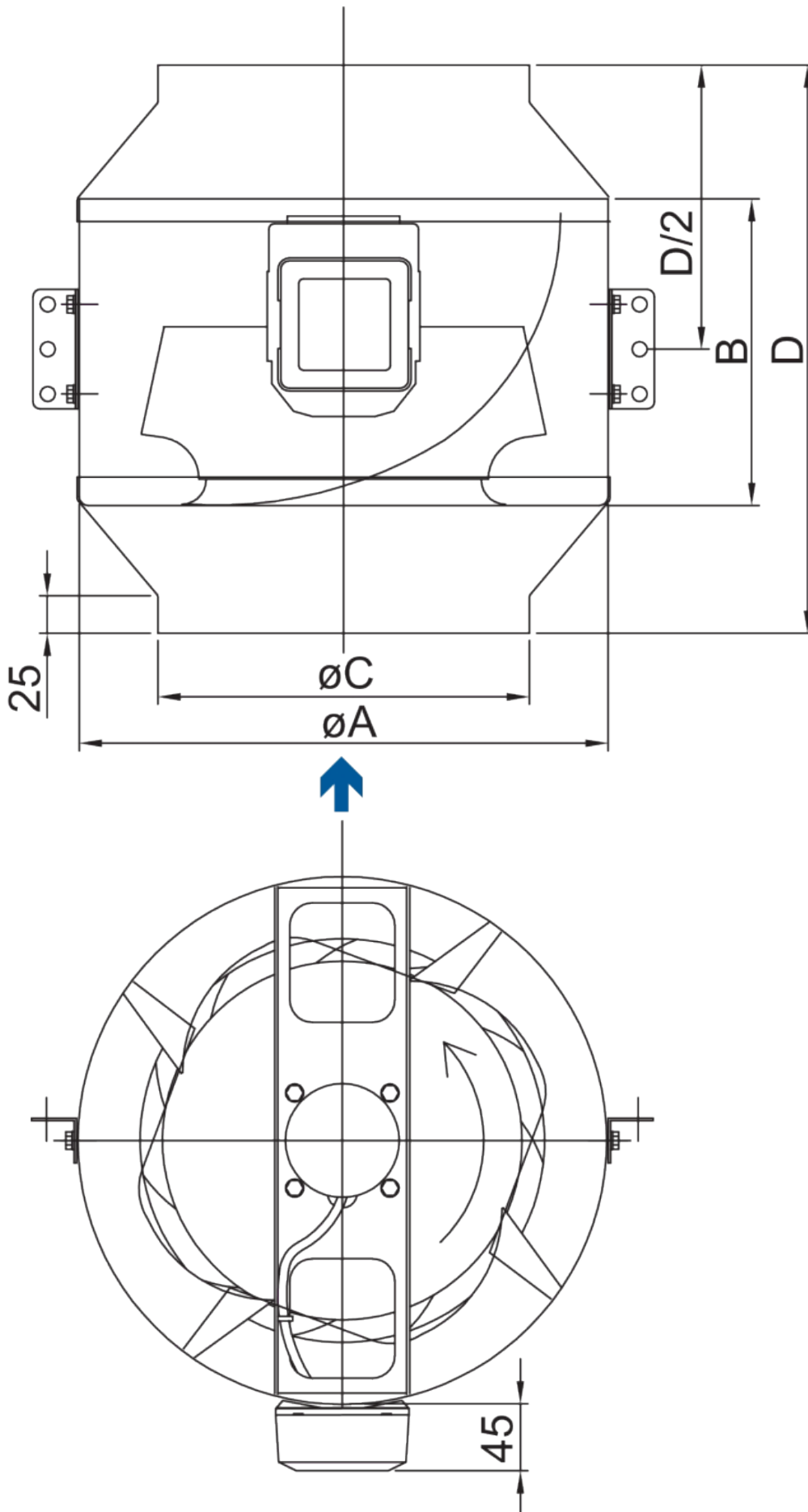

	øA	B	øC	D	D/2
KD 200 L	313	180	198	380	190
KD 250 M	313	180	248	310	155
KD 250 L	353	205	248	385	192,5

Wiring

230V 1~

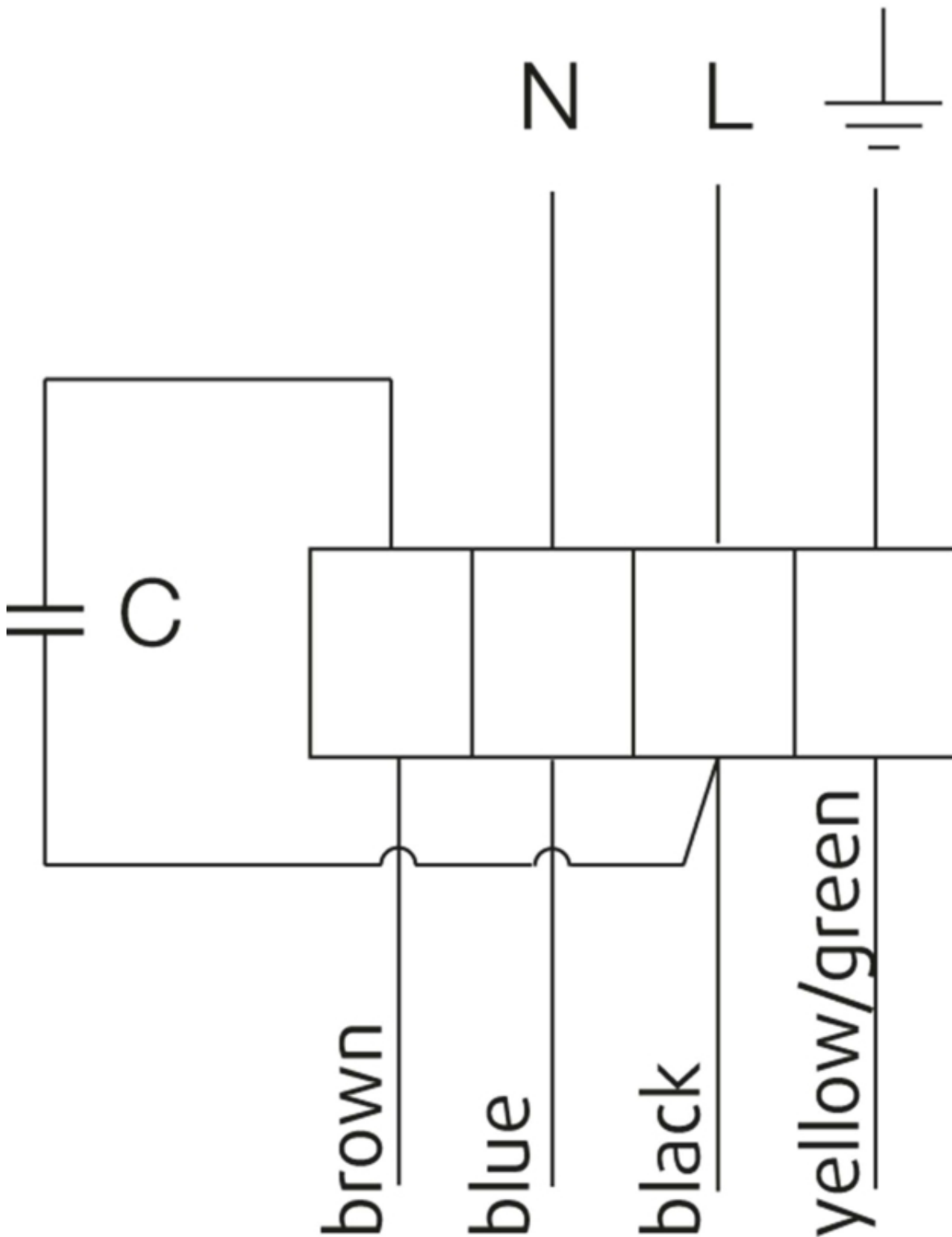

U1 = blue = blau
U2 = black = schwarz
Z = brown = braun
PE = yellow/green = grün-gelb

Accessories

Electric accessories

[RE 3 Speed control \(5001\)](#)
[REU 3 Speed control \(5005\)](#)
[REE 2 Speed control \(5316\)](#)
[REPT 6 Digital regulator \(5698\)](#)
[RT 0-30 Room Thermostat \(5151\)](#)
[CO2RT-R-D Transmitter \(6993\)](#)
[Presence detector/IR24-P \(6995\)](#)
[STL 3 Speed controller \(84261\)](#)
[REV-3POL/03 ON/OFF \(33978\)](#)
[FRQS-E-6A \(37419\)](#)
[FRQ5S-E-6A \(37421\)](#)

Accessories

[CB 250-9,0 400V/3 Duct heater \(5373\)](#)
[CB 250-3,0 230V/1 Duct heater \(5385\)](#)
[VBF 250 Water heating battery \(1733\)](#)
[CWK 250-3-2,5 Duct cooler.circ \(30024\)](#)
[VBC 250-2 Water heating batt \(5460\)](#)
[LDC 250-900 Silencer \(5196\)](#)
[FFR 250 Filter cassette \(1776\)](#)
[FGR 250 Filter cassette \(1815\)](#)
[FK 250 Fast clamp \(1612\)](#)
[VKK-250 Back draft damper \(1627\)](#)
[RSK-250 Back draft damper \(5603\)](#)
[SG 250 Protection guard \(5610\)](#)
[VK-25 Louvre shutter \(5640\)](#)
[CBM 250-6,0 400V/2 Duct heater \(9089\)](#)
[VBC 250-3 Water heating batt \(9843\)](#)
[CB 250-6,0 400V/2 Duct heater \(5372\)](#)

Documentation

 [132780_Fans_Instructions_Outside_EU_A002.pdf \(1 006,63kB\)](#)

Specification text

The Circular duct fan is reliable in operation and maintenance- free and has a backward-curved mixed flow impeller. In addition to that the fan achieves a high efficiency at low noise level. For an easy assembling the installation brackets are fixed to the fan. The provided standard connecting collar of the FK - mounting bracket assures an easy assembling and disassembling and avoids the transmission of vibration to the piping system. The assembling is possible in each fitting position. The actuation is carried out by a maintenance- free, speed- controlled external rotor motor. Through dropping the tension, the fans can be speed- controlled with the help of a stepless thyristor or a 5- step transformer. The fans have integral thermal contacts with reset device according to EN 60335-2-80 for protecting the engine. For annealing the engine is designed inside the air flow. Completely with the impeller in two levels the engine is statically and dynamically weighed heavy according DIN ISO 1940.