

KD 450 XL1 CIRC. DUCT FAN

Item no. 19546

Document type: **Product card**
 Document date: **2019-07-16**
 Generated by: **Systemair Online Catalogue**

Description

- High efficiency – low noise
- Speed-controllable
- Integral thermal contacts
- Can be installed in any position
- Maintenance-free and reliable

The KD series have external rotor motors with a new type of mixed flow impeller which reduces the external dimensions of the fans. These fans have a high capacity in relation to their compact design. Brackets are supplied with the fans to make installation easier. The FK mounting clamp facilitates easy installation and removal and prevents the transfer of vibrations to the duct. To protect the motor from overheating the fan has integral thermal contacts with leads to a motor protection device. The casing is manufactured from galvanised sheet steel.



Technical parameters

Nominal data		
Voltage	230	V
Frequency	50	Hz
Phase	1	~
Input power (P1)	1392	W
Current	6,16	A
Max. airflow	2,35	m³/s
R.p.m.	1289	r.p.m.
Capacitor	30	µF
Weight	37	kg
Temperature data		
Max. temperature of transported air	60	°C
Max. temperature of transported air when speed-controlled	60	°C
Sound data		
Sound pressure level at 3 m	60,9	dB(A)
Protection / Classification		
Insulation class		F
Enclosure class, motor		IP54

Diagrams

Diagrams

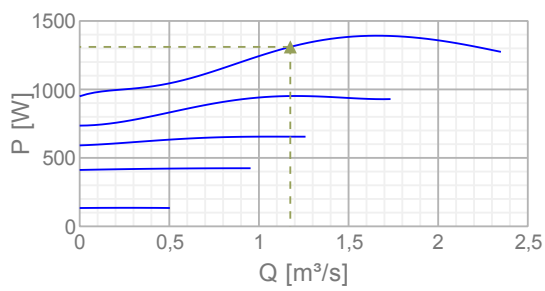
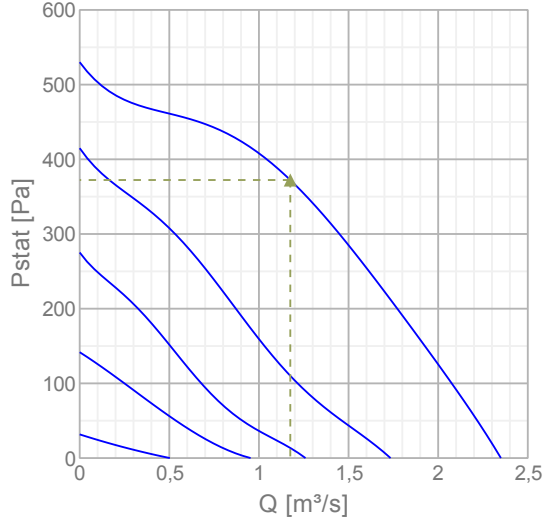

Max efficiency

Hydraulic data										
▲ Working air flow										1,18 m³/s
▲ Working static pressure										372 Pa
▲ Power										1310 W
Speed										1315 r.p.m.
Current										5,75 A
SFP										1,12 W/(l/s)
Voltage										230 V
Sound power level		63	125	250	500	1k	2k	4k	8k	Tot
Inlet	dB(A)	69	76	75	75	74	73	66	59	82
Outlet	dB(A)	69	76	73	76	76	72	67	61	82
Surrounding	dB(A)	35	54	60	65	61	59	46	40	68

Dimensions

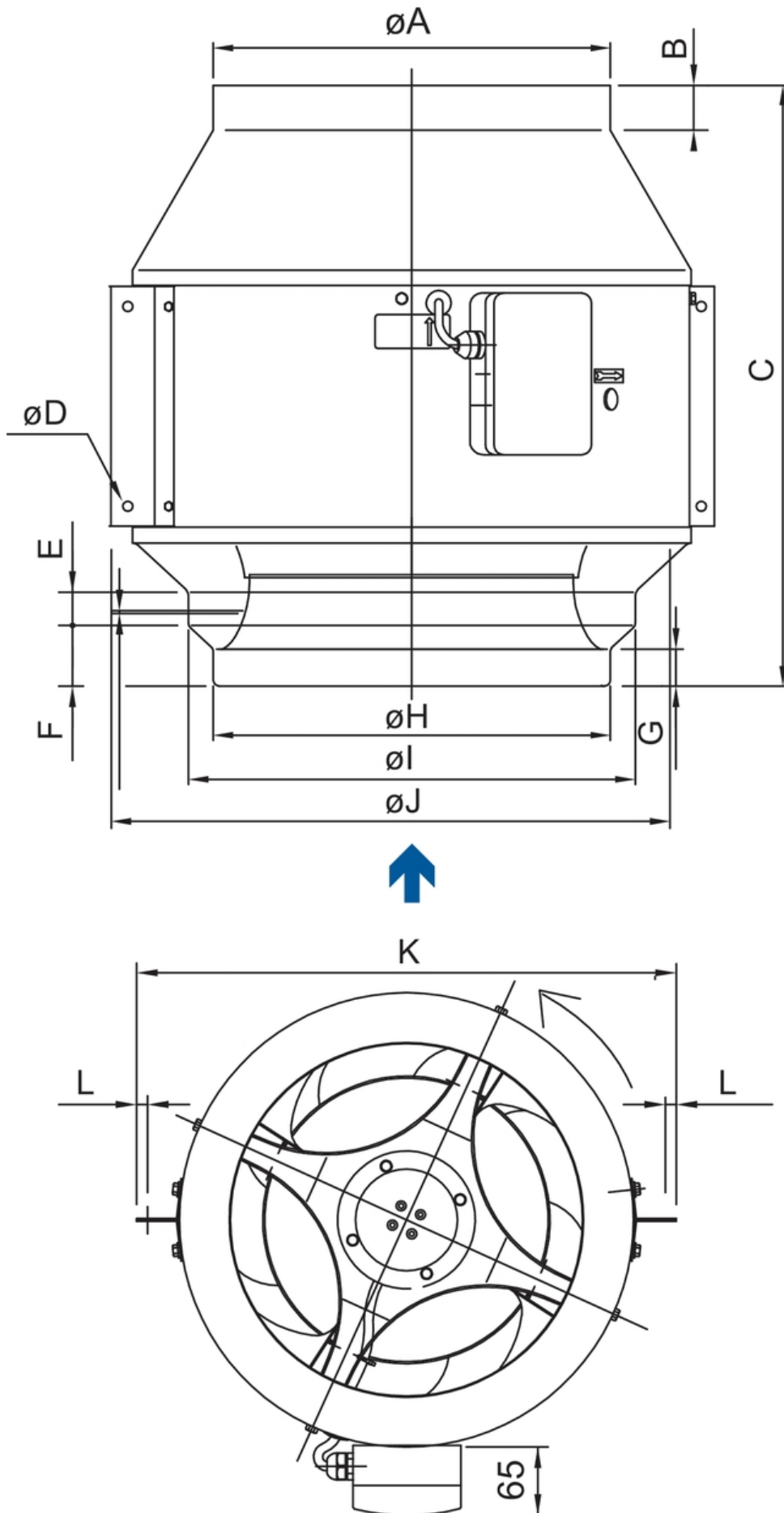

	øA	B	C	øD (x4)	E	F	G	øH	øI	øJ	K	L
KD 400 M	400	40	480	10	38	59	38	355	400	503	590	11
KD 400 XL	400	44	602	12	33	61	37	400	450	560	662	18,5
KD 450 M	450	44	559	12	33	61	37	400	450	560	662	18,5
KD 450 XL	450	46	686	12	45	76	50	450	500	660	812	18,5
KD 500 M	500	46	643	12	45	76	50	450	500	660	812	18,5

Wiring

230V 1~

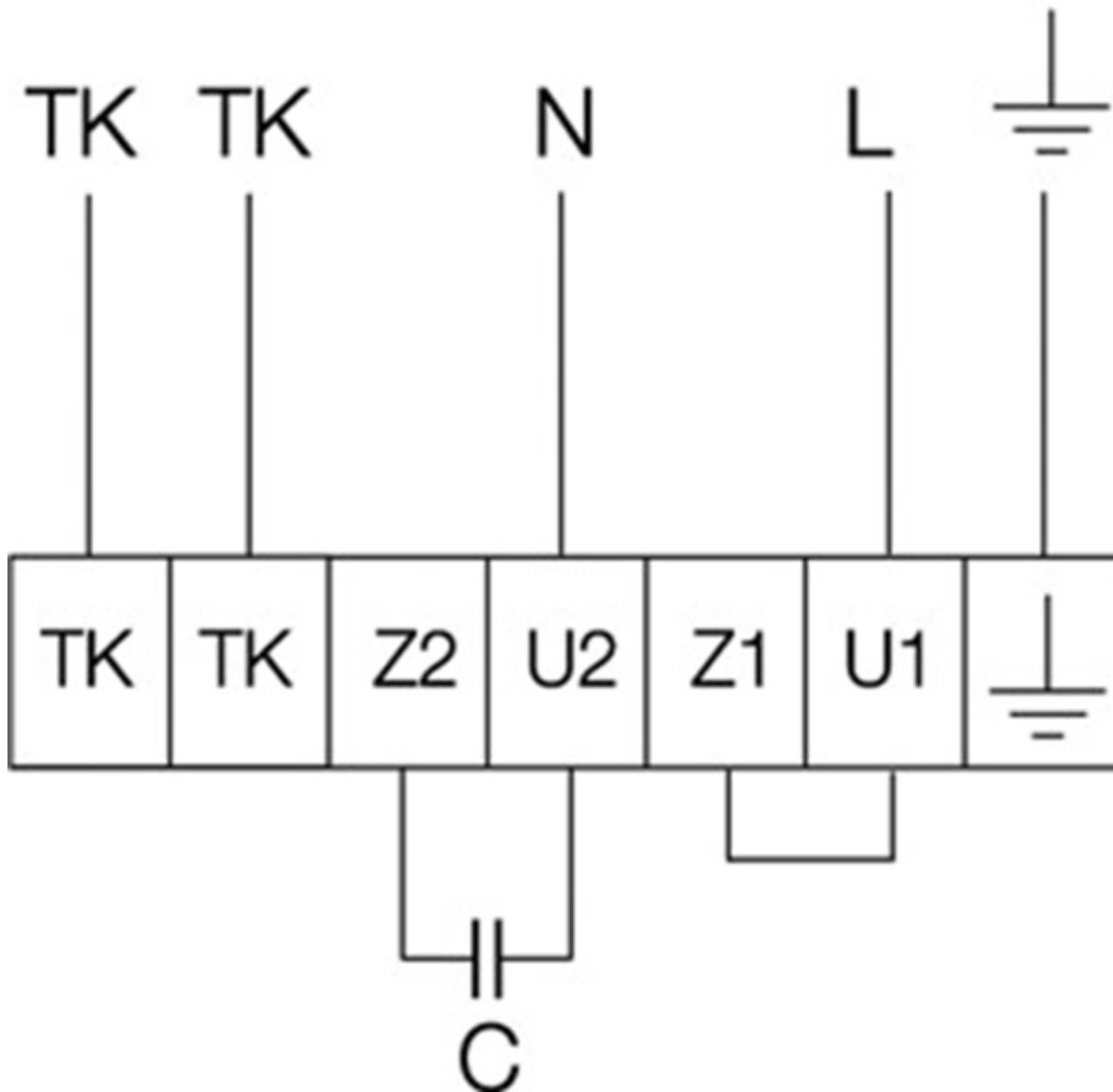

Accessories

Electric accessories

[REU 7 Speed control \(5007\)](#)

[RTRE 7 Speed control \(5011\)](#)

[S-ET 10 Motor Protection \(5154\)](#)

[STL 10 Speed controller \(84272\)](#)

[REV-5POL/05 ON/OFF \(33979\)](#)

Accessories

[FK 450 Fast clamp \(1616\)](#)

[SG 450 Protection guard \(5614\)](#)

[VK-45 Louvre shutter \(5645\)](#)

[RSK-450 Back draft dmp. \(9768\)](#)

Documentation



132780_Fans_Instructions_Outside_EU_A002.pdf (1 006,63kB)