

## KE 60-30-6 REC. FAN

Item no. 19551

Version: 50 Hz

Document type: **Product card**  
 Document date: **2019-07-16**  
 Generated by: **Systemair Online Catalogue**

### Description

- Swing-out
- Speed-controllable
- Integral thermal contacts
- Can be installed in any position
- Maintenance-free and reliable

The KE models have impellers with forward-curved blades and external rotor motors. The motor and impeller are mounted on the access cover to facilitate easy maintenance. The casing is manufactured from galvanised sheet steel. To protect the motor from overheating the fans have integral thermal contacts with external leads for connection to a motor protection device. The fans can be installed in any position and are easy to connect using the DS flexible connections. The KE fans have a pre-wired, integral terminal box.



### Technical parameters

Nominal data		
Voltage	230	V
Frequency	50	Hz
Phase	1	~
Input power (P1)	493	W
Current	2,3	A
Max. airflow	0,659	m <sup>3</sup> /s
R.p.m.	898	r.p.m.
Min. static back pressure	0	Pa
Capacitor	14	µF
Weight	30,3	kg
Temperature data		
Max. temperature of transported air	70	°C
Max. temperature of transported air when speed-controlled	70	°C
Sound data		
Sound pressure level at 3 m	54,7	dB(A)
Protection / Classification		
Insulation class	F	
Enclosure class, motor	IP54	

## Diagrams

### Diagrams

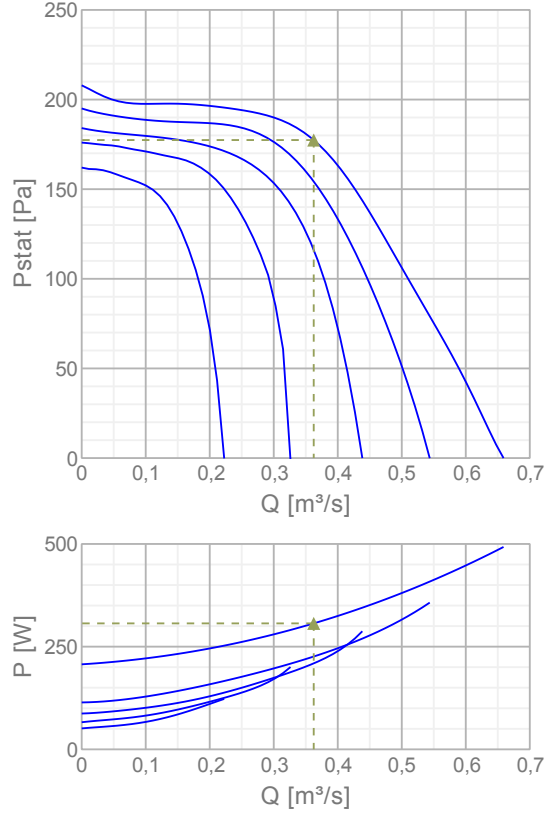

### Max efficiency

Hydraulic data										
▲ Working air flow										0,362 m³/s
▲ Working static pressure										177 Pa
▲ Power										307 W
Speed										956 r.p.m.
Current										1,58 A
SFP										0,846 W/(l/s)
Voltage										230 V
Sound power level		63	125	250	500	1k	2k	4k	8k	Tot
Inlet	dB(A)	64	66	63	60	62	63	59	53	71
Outlet	dB(A)	55	65	62	69	70	67	65	57	75
Surrounding	dB(A)	56	51	58	50	51	49	44	38	62

## Dimensions

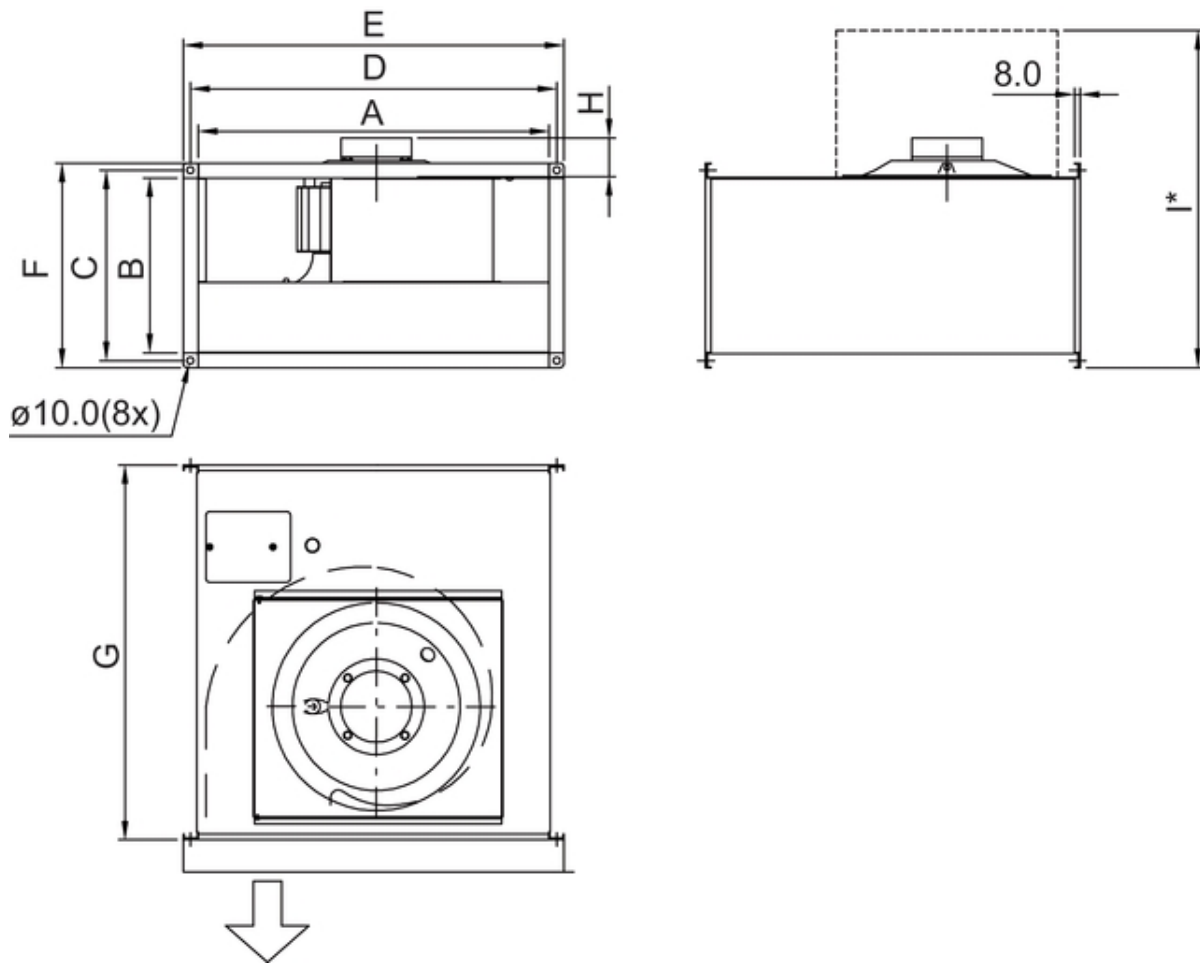

I\* = Dimension with fully open hatch.

	A	B	C	D	E	F	G	H	I*
KE 40-20	398	198	220	420	440	240	502	32	530
KE 50-25	498	248	270	520	540	290	532	34	610
KE 50-30	498	298	320	520	540	340	562	34	695
KE 60-30	598	298	320	620	640	340	642	47	715
KE 60-35	598	348	370	620	640	390	717	50	805

## Wiring

230V 1~

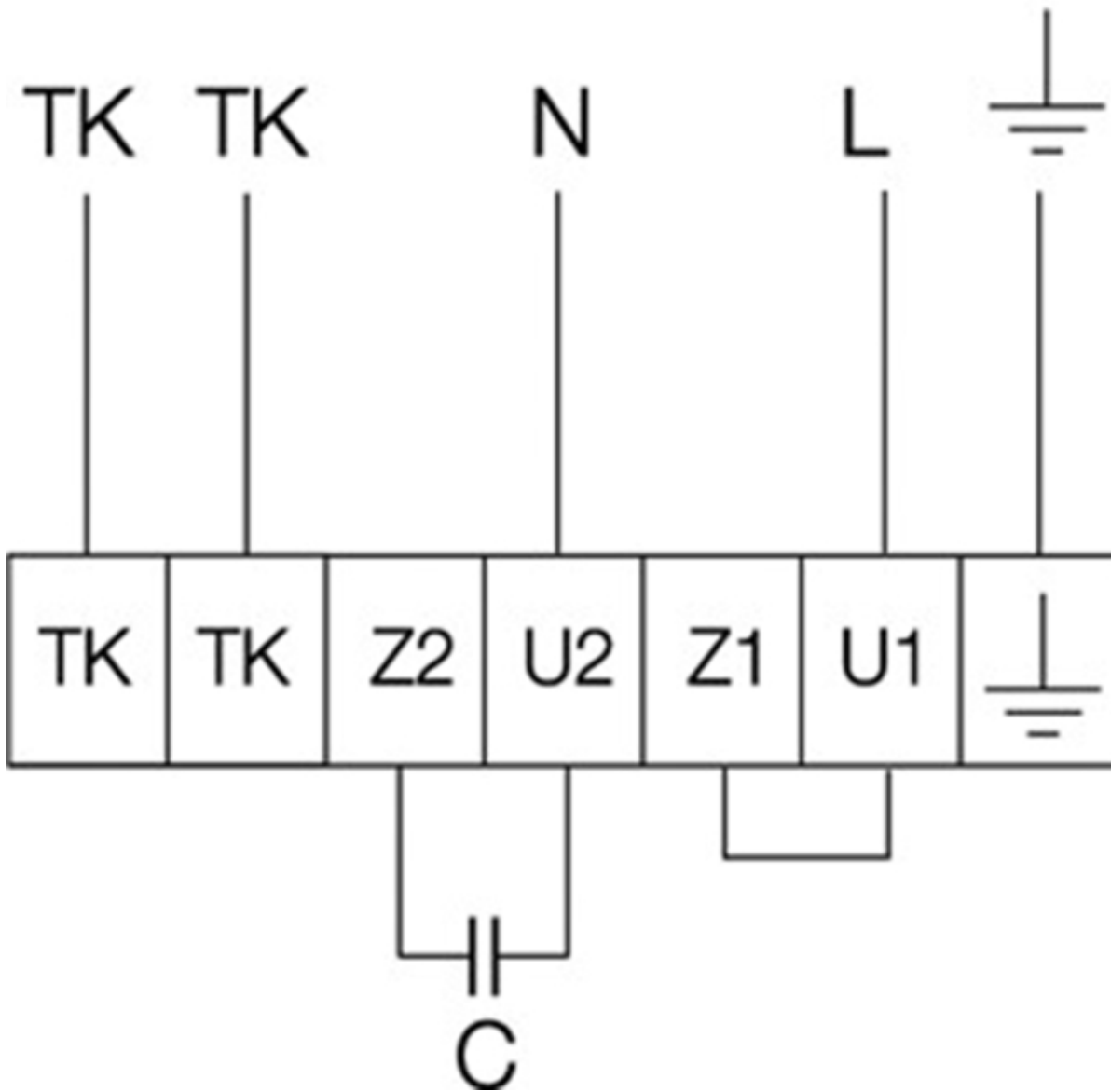

## Accessories

### Electric accessories

[REU 3 Speed control \(5005\)](#)

[RTRE 3 Speed control \(5009\)](#)

[REE 4 Speed control \(5317\)](#)

[REPT 6 Digital regulator \(5698\)](#)

[RT 0-30 Room Thermostat \(5151\)](#)

[S-ET 10 Motor Protection \(5154\)](#)

[S-ET 10E Motor Protection \(5155\)](#)

[CO2RT-R-D Transmitter \(6993\)](#)

[Presence detector/IR24-P \(6995\)](#)

[RETP 6 Temp/Pressure regulator \(32293\)](#)

[STL 3 Speed controller \(84261\)](#)

[REV-5POL/05 ON/OFF \(33979\)](#)

[FRQS-E-6A \(37419\)](#)

[FRQ5S-E-6A \(37421\)](#)

[DTV500A \(96807\)](#)

## Accessories

[RBM 60-30/27 400V/3 Duct heate \(5453\)](#)  
[PGK 60-30-3-2,0 Duct cooler \(6610\)](#)  
[VBR 60-30-2 Water heating batt \(5466\)](#)  
[VBR 60-30-4 Water heating batt \(5474\)](#)  
[LDR 60-30 Silencer \(5072\)](#)  
[FFK 60-30 Filter cassette rect \(1758\)](#)  
[DS 60-30 Flexible connection \(1547\)](#)  
[GFL 60-30 Counter flange \(2708\)](#)  
[VK-60-30 Louvre shutter \(5649\)](#)  
[SRK 60-30 Class 3 Damper \(7023\)](#)  
[DXRE 60-30-3-2,5 Duct cooler \(7955\)](#)  
[RB 60-30/22-2 400V/3 Duct heat \(9638\)](#)  
[RB 60-30/34-2 400V/3 Duct heat \(9641\)](#)  
[RKT-SYS-600x300-S \(43632\)](#)  
[RK-SYS-600x300-R \(43646\)](#)  
[RK-SYS-600x300-S \(43655\)](#)

## Documentation



132780\_Fans\_Instructions\_Outside\_EU\_A002.pdf (1 006,63kB)

## Specification text