

KT 40-20-4

Item no. 1482

Version: 50 Hz

Document type: **Product card**
 Document date: **2019-07-10**
 Generated by: **Systemair Online Catalogue**



Description

- Swing-out
- Speed-controllable
- Integral thermal contacts
- Can be installed in any position
- Maintenance-free and reliable

The KT models have impellers with forward-curved blades and external rotor motors. The motor and impeller are mounted on the access cover to facilitate easy maintenance. The casing is manufactured from galvanised sheet steel. To protect the motor from overheating the fans have integral thermal contacts with external leads for connection to a motor protection device. The fans can be installed in any position and are easy to connect using the DS flexible connections. The KT fans have a pre-wired, integral terminal box.



Technical parameters

Nominal data		
Voltage	400	V
Frequency	50	Hz
Phase	3	~
Input power (P1)	289	W
Current	0,519	A
Max. airflow	0,368	m ³ /s
R.p.m.	1303	r.p.m.
Min. static back pressure	0	Pa
Weight	12,5	kg
Temperature data		
Max. temperature of transported air	63,4	°C
Max. temperature of transported air when speed-controlled	63,4	°C
Sound data		
Sound pressure level at 3 m	52	dB(A)
Protection / Classification		
Insulation class		B
Enclosure class, motor		IP44

Diagrams

Diagrams

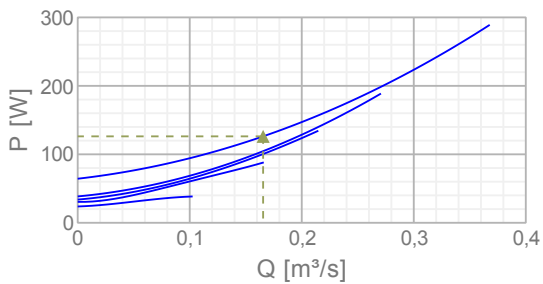
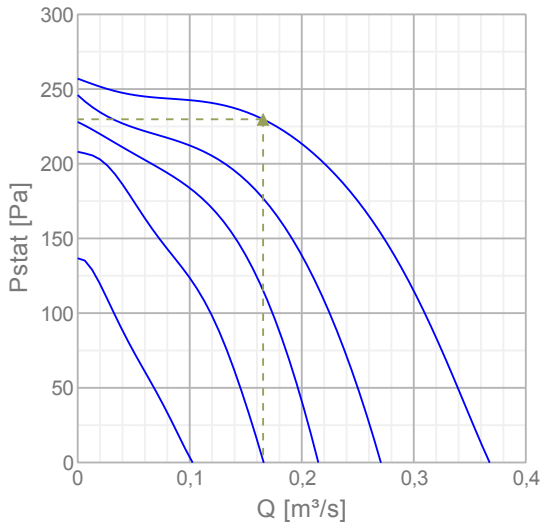

Max efficiency

Hydraulic data

▲ Working air flow	0,166 m³/s
▲ Working static pressure	230 Pa
▲ Power	126 W
Speed	1434 r.p.m.
Current	0,365 A
SFP	0,763 W/(l/s)
Voltage	400 V

Sound power level		63	125	250	500	1k	2k	4k	8k	Tot
Inlet	dB(A)	57	68	64	61	57	56	54	48	71
Outlet	dB(A)	54	64	68	65	66	63	60	54	73
Surrounding	dB(A)	35	47	58	52	50	45	41	36	60

Dimensions

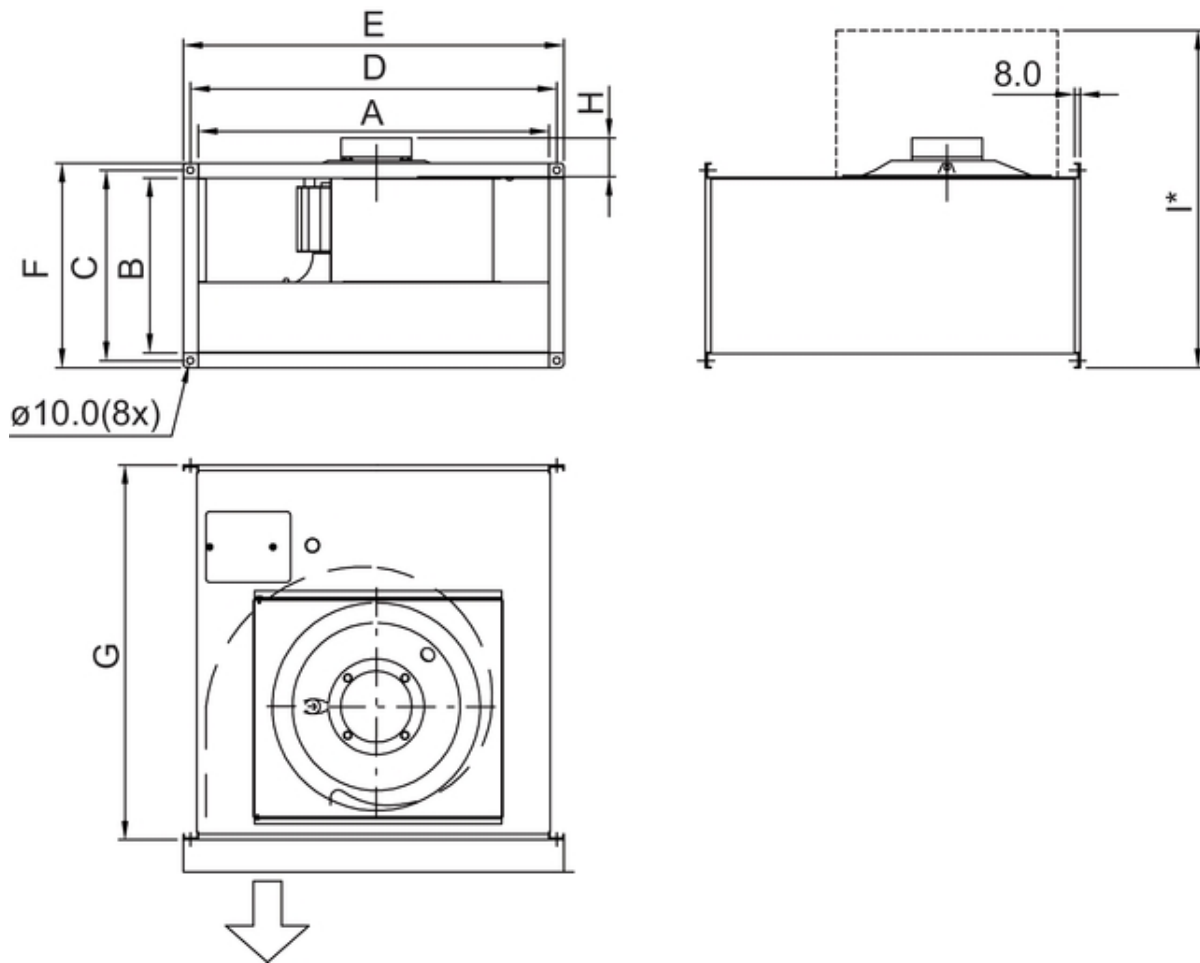

	A	B	C	D	E	F	G	H	I*
KT 40-20	398	198	220	420	440	240	502	32	530
KT 50-25	498	248	270	520	540	290	532	68	610
KT 50-30	498	298	320	520	540	340	562	68	695
KT 60-30	598	298	320	620	640	340	642	89	715
KT 60-35	598	348	370	620	640	390	717	92	805
KT 70-40-4	698	398	420	720	740	440	787	92	900
KT 70-40-6/8	698	398	420	720	740	440	787	92	900
KT 80-50	798	497	520	820	840	540	880	113	1090
KT 100-50	998	497	520	1020	1040	540	980	113	1140

I* = Dimension with fully open hatch.

Wiring

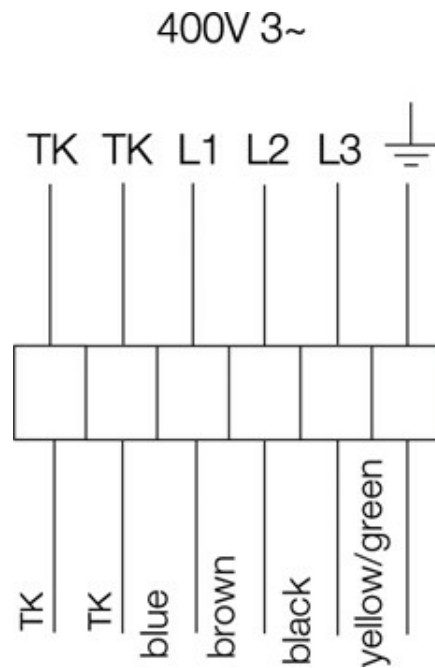

Accessories

Electric accessories

- [RTRD 2 Speed Cont. Systemair \(5941\)](#)
- [RTRDU 2 Speed contr. Systemair \(5945\)](#)
- [RT 0-30 Room Thermostat \(5151\)](#)
- [STDT 16 Motor Protection \(5152\)](#)
- [STDT 16E Motor Protection \(5153\)](#)
- [CO2RT-R-D Transmitter \(6993\)](#)
- [Presence detector/IR24-P \(6995\)](#)
- [DTV200 \(6261\)](#)
- [REV-5POL/07 ON/OFF \(33980\)](#)
- [DTV500A \(96807\)](#)

Accessories

- [RBM 40-20/9 400V/3 Duct heater \(5450\)](#)
- [PGK 40-20-3-2,0 Duct cooler \(6604\)](#)
- [VBR 40-20-2 Water heating batt \(5463\)](#)
- [VBR 40-20-4 Water heating batt \(5471\)](#)
- [LDR 40-20 Silencer \(5069\)](#)
- [FFK 40-20 Filter cassette rect \(1750\)](#)
- [DS 40-20 Flexible connection \(1539\)](#)
- [GFL 40-20 Counter flange \(2705\)](#)
- [SRK 40-20 Class 3 Damper \(7020\)](#)
- [DXRE 40-20-3-2,5 Duct cooler \(7951\)](#)
- [RB 40-20/15-1 400V/3 Duct heat. \(9628\)](#)
- [RB 40-20/9-1 400V/3 Duct heat. \(9627\)](#)
- [RKT-SYS-400x200-S \(43629\)](#)
- [RK-SYS-400x200-R \(43643\)](#)
- [RK-SYS-400x200-S \(43652\)](#)

Documentation

 [202341_Fans_Instructions_CE_A010.pdf \(1,83MB\)](#)