

KVADRA-225 DIFFUSER

Item no. 6541

Document type: **Product card**
 Document date: **2019-07-10**
 Generated by: **Systemair Online Catalogue**

Description

Systemair Kvadra square 4-way ceiling diffuser with connection transition KRC and plenum box PER as accessories.

Function

Kvadra supply- and exhaust diffuser for ceiling installation. The diffuser can be used in offices, shops or similar premises. It can be connected to square ducts or circular ducts via connection transition KRC and to PER plenum box. The diffuser can be dismantled for duct cleaning. Kvadra has a high induction which makes it suitable for cooled air. Maximum temperature difference is dT 12 K.

Design

Kvadra is manufactured from galvanized sheet metal with a white powder-coated finish (RAL 9010) and is available in the following sizes: (square) 150x150, 225x225, 300x300, 450x450, and with KRC (circular) 125, 160, 250, 315 and 400. The connection transition KRC is manufactured from galvanized sheet metal and is equipped with a perforated metal sheet for pressure distribution and is simple to connect.

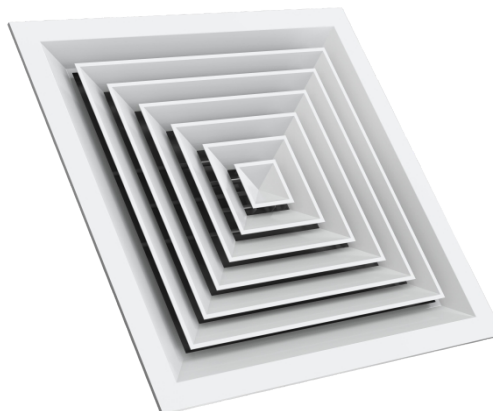

How to use for exhaust air

This device can be used for exhaust air.

Mounting

Correct adjustment requires a length of straight duct, 4 times the duct diameter in front of the PER plenum box. The distribution unit is connected to the duct with screws or pop rivets. Dismantling of the supply air unit: release the cones by gently pressing and turning the cones simultaneously. Reassemble the unit correspondingly.

When assembling KRC to the Kvadra diffuser, make sure that Kvadra's connection edges fits into the KRC hold down springs. Gentle tap the two parts together so that Kvadra's connection edges bottoms into the hold down springs.

Technical parameters

Other	
Weight	1,2 kg

Dimensions

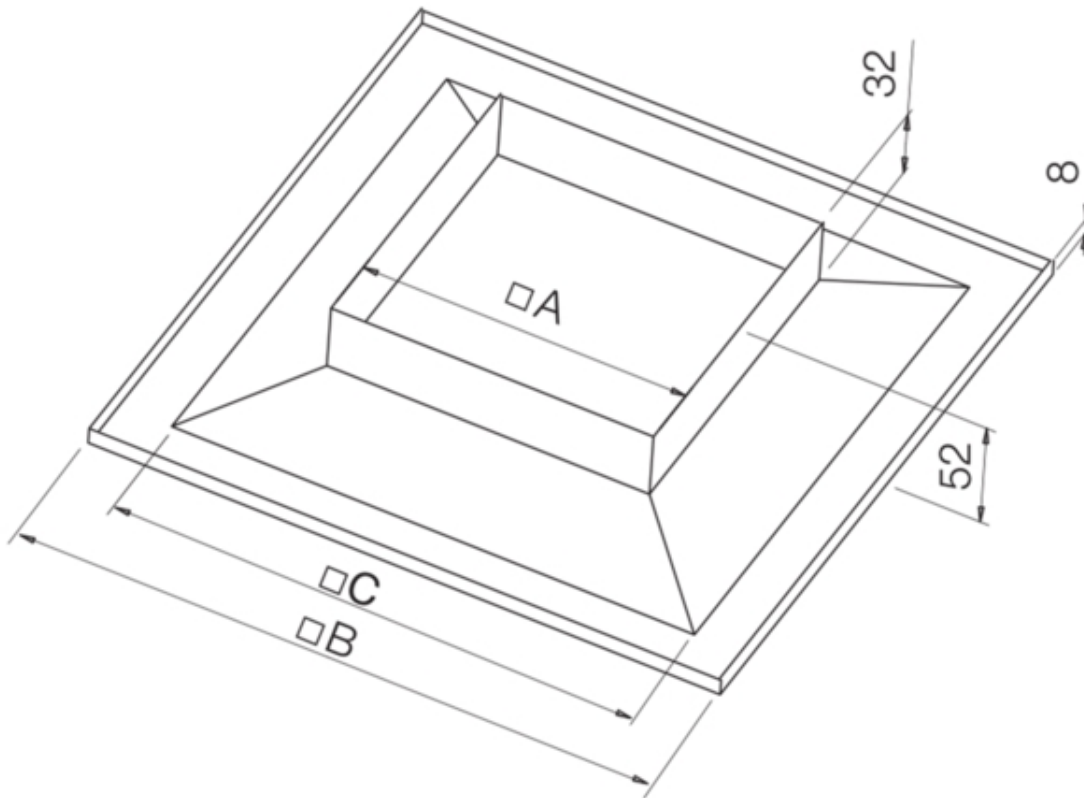

Kvadra	□A	□B	□C
150	150	294	210
225	225	369	285
300	300	444	360
375	375	519	435
450	450	594	510

Accessories

Accessories

[KRC-225 Transition Kvadra \(6531\)](#)

[Kvadra-R1 225 Damper \(42302\)](#)

[THOR-125-160 \(66759\)](#)

Documentation

Diagram

The diagram shows

Air volume (l/s and m³/h), total pressure (Pa), throw (l0,2) and sound pressure level [dB(A)].

Sound attenuation, ΔL (dB)

	Mid-frequency band, Hz							
	63	125	250	500	1k	2k	4k	8k
Kvadra-150	21	17	12	6	-1	2	2	2
Kvadra-225	19	14	10	4	-1	2	2	2
Kvadra-300	21	11	7	2	0	1	2	2
Kvadra-375	16	10	6	1	0	1	2	2
Kvadra-450	14	8	3	1	0	1	2	2
KRC + PER								
Kvadra-150	22	18	15	18	11	13	10	15
Kvadra-225	24	19	15	16	11	12	11	12
Kvadra-300	18	12	15	15	10	10	12	11
Kvadra-375	14	12	10	12	10	8	10	11
Kvadra-450	15	12	13	12	7	7	8	10

Sound power level, Lw

Lw(dB) = LpA + Kok (LpA = diagram Kok = table)
correction factor Kok

	63	125	250	500	1k	2k	4k	8k
Kvadra-150	16	6	5	2	-2	-9	-20	-26
Kvadra-225	15	9	8	2	-5	-11	-22	-26
Kvadra-300	9	3	9	1	-4	-10	-19	-23
Kvadra-375	10	9	9	1	-6	-15	-26	-27
Kvadra-450	17	8	11	-4	-10	-19	-25	-24
KRC								
Kvadra-150	11	-1	2	4	-1	-9	-19	-24
Kvadra-225	16	4	4	2	-2	-6	-12	-14
Kvadra-300	11	3	6	0	-1	-5	-19	-20
Kvadra-375	7	9	7	0	-2	-6	-22	-23
Kvadra-450	12	7	9	-1	-4	-8	-25	-25
KRC + PER								
Kvadra-150	12	5	7	1	-1	-9	-18	-22
Kvadra-225	11	6	7	1	-1	-11	-19	-17
Kvadra-300	12	8	4	0	-1	-7	-12	-17
Kvadra-375	16	9	3	0	-1	-7	-14	-18
Kvadra-450	16	8	4	0	-1	-11	-18	-25
Tolerance	±6	±3	±2	±2	±2	±2	±3	±4

