

# KV 100 XL SILEO

Item no. 25368

Version: 50 Hz

Document type: **Product card**  
 Document date: **2019-07-10**  
 Generated by: **Systemair Online Catalogue**



## Description

- Speed-controllable
- Quiet-running
- Increased efficiency
- Integral thermal contacts
- Can be installed in any position - duct or wall mounted
- Can be installed outdoors
- Maintenance-free and reliable

The KV sileo series is designed for installation in ducts. All KV-fans have minimum 25 mm long spigot connections. The FK mounting clamp facilitates easy installation and removal, and prevents the transfer of vibration to the duct. The fans have backward-curved blades and external rotor motors. KV sileo fans can be speed-controlled via a stepless thyristor or a 5-step transformer.

To protect the motor from overheating the fan has integral thermal contacts with manual reset.

The casing is manufactured from galvanised sheet steel and folded which gives the fan a close to air tight casing, wet room applications of the fan are possible due to the air tight casing.

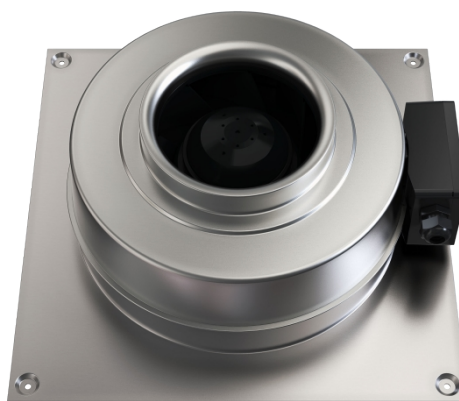

## Technical parameters

Nominal data		
Voltage	230	V
Frequency	50	Hz
Phase	1	~
Input power (P1)	51,3	W
Current	0,224	A
Max. airflow	0,0925	m <sup>3</sup> /s
R.p.m.	2443	r.p.m.
Capacitor	1,5	µF
Weight	2,8	kg
Temperature data		
Max. temperature of transported air	70	°C
Max. temperature of transported air when speed-controlled	70	°C
Sound data		
Sound pressure level at 3 m	44,4	dB(A)

Protection / Classification	
Insulation class	B
Enclosure class, motor	IP44
ErP	
Energy class, basic unit	<b>E</b>
Energy class, basic unit option	<b>C</b>
ErP ready	ErP 2016/ErP 2018

## Energy class label

### Energy class, basic unit

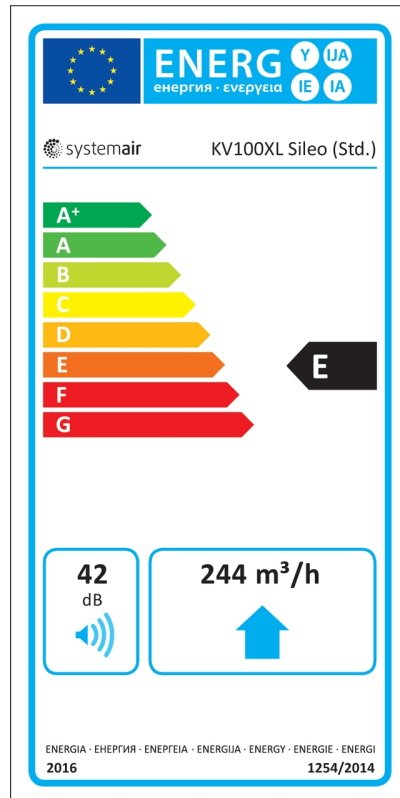

## Energy class, unit with local demand control

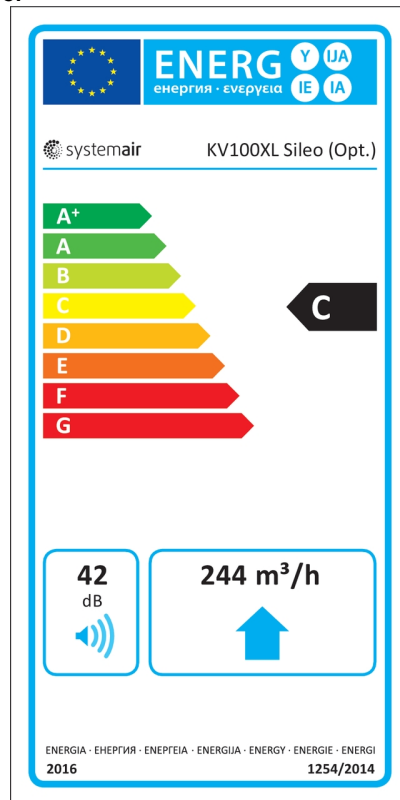

## Diagrams

### Diagrams

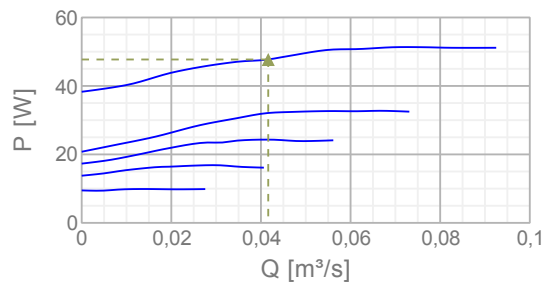
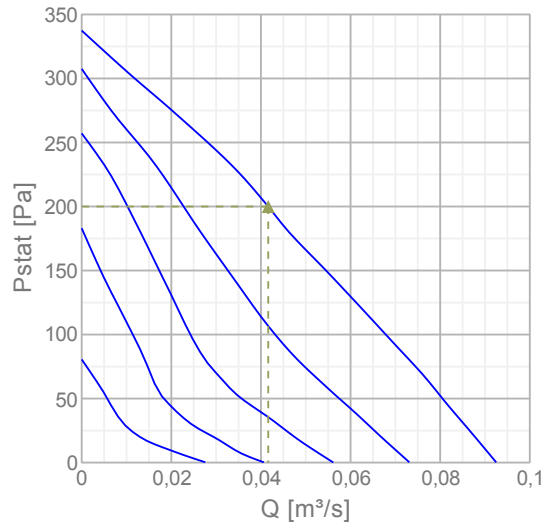

## Max efficiency

Hydraulic data										
▲ Working air flow										0,0416 m <sup>3</sup> /s
▲ Working static pressure										200 Pa
▲ Power										47,7 W
Speed										2527 r.p.m.
Current										0,21 A
SFP										1,15 W/(l/s)
Voltage										230 V
Sound power level		63	125	250	500	1k	2k	4k	8k	Tot
Inlet	dB(A)	57	59	61	62	60	58	48	35	68
Outlet	dB(A)	35	41	50	63	64	63	55	46	68
Surrounding	dB(A)	29	25	33	45	45	42	36	19	49

## Dimensions

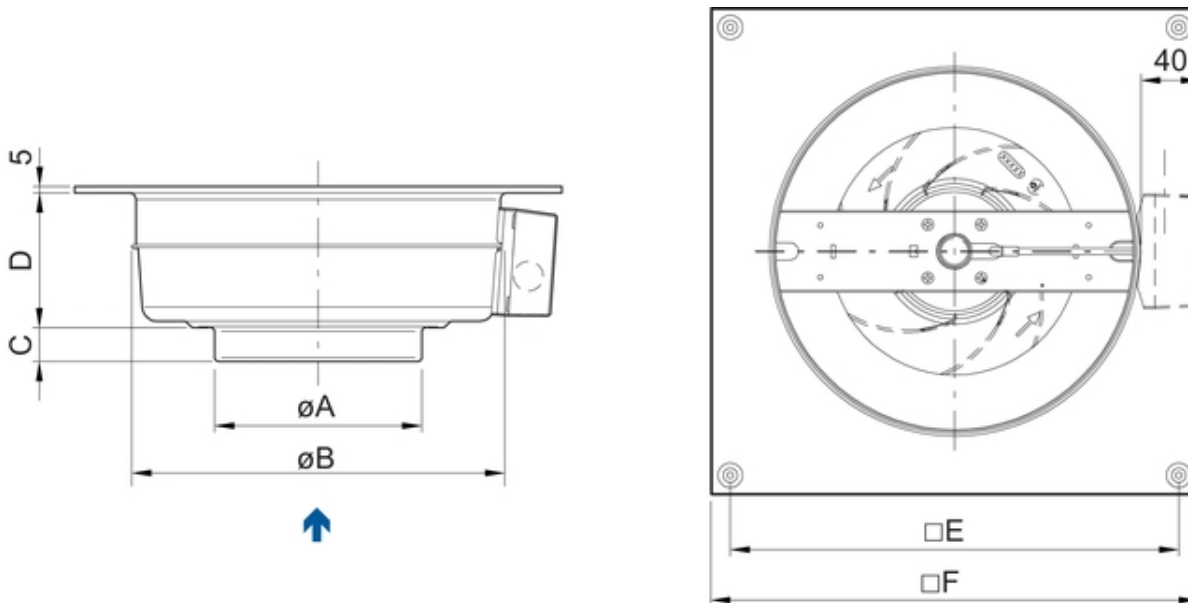

	øA	øB	C	D	øE	øF
<b>KV 100 XL</b>	99	246	26	125	304	334

230V 1~

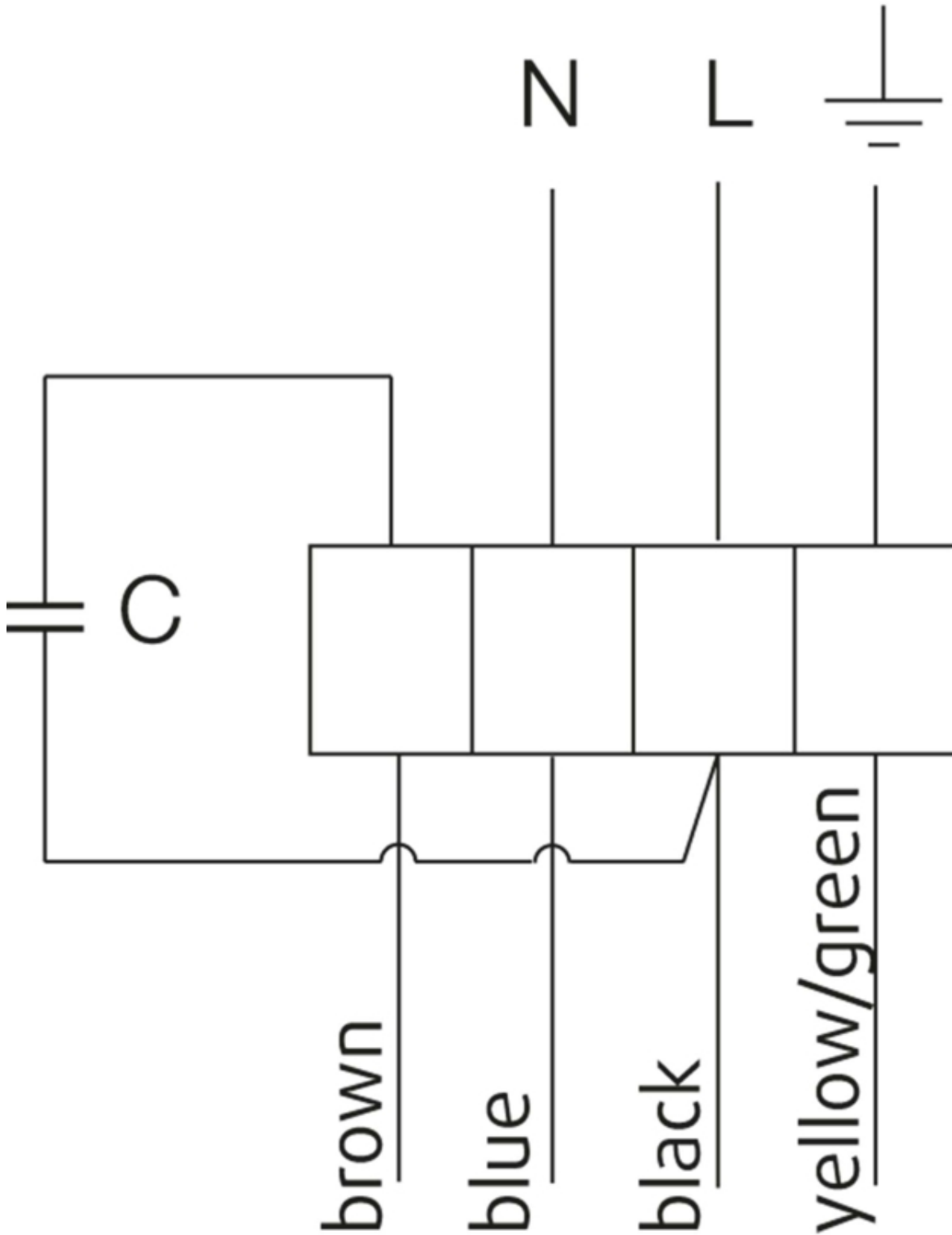

...

## Accessories

### Electric accessories

[RE 1.5 Speed control \(5000\)](#)  
[REU 1.5 Speed control \(5004\)](#)  
[REE 1 Speed control \(5314\)](#)  
[REPT 6 Digital regulator \(5698\)](#)  
[RT 0-30 Room Thermostat \(5151\)](#)  
[CO2RT-R-D Transmitter \(6993\)](#)  
[Presence detector/IR24-P \(6995\)](#)  
[DTV200 \(6261\)](#)  
[REV-3POL/03 ON/OFF \(33978\)](#)  
[DTV500A \(96807\)](#)

### Accessories

[CBM 100-0,6 230V/1 Duct heater \(5479\)](#)  
[CWK 100-3-2,5 Duct cooler.circ \(30019\)](#)  
[VBC 100-2 Water heating batt \(5456\)](#)  
[LDC 100-600 Silencer \(5188\)](#)  
[LDC 100-900 Silencer \(5189\)](#)  
[FFR 100 Filter cassette \(1766\)](#)  
[FGR 100 Filter cassette \(1802\)](#)  
[FK 100 Fast clamp \(1607\)](#)  
[VKK-100 Back draft damper \(1623\)](#)  
[IGK-100 Wall Grid \(1630\)](#)  
[RSK-100 Back draft damper \(5597\)](#)  
[SG 100 Protection guard \(5606\)](#)  
[VK-25 Louvre shutter \(5640\)](#)  
[LDC 100-300 Silencer \(8180\)](#)  
[LDC 100-1200 Silencer \(5996\)](#)  
[VBC 100-3 Water heating batt \(9838\)](#)

## Documentation



202341\_Fans\_Instructions\_CE\_A010.pdf (1,83MB)

## Specification text

KV 100XL TW Circular duct fan  
DN100, 230V50Hz, 1~, LR imp. backw. curved

Circular duct fan for wall mounting, easy and direct installation in ducts.  
Galvanized sheet steel housing.  
Circular connection spigot, length 25mm, acc. to EN1506:1997

Free-running, backward curved centrifugal impeller made of plastic.  
Balancing made to G 6.3, motor compl. with impeller statically and dynamically balanced in two planes acc. to DIN ISO 1940 T.1.

Voltage controllable external rotor motor, maintenance-free, the motor is placed inside the air flow for cooling. Integral thermal contacts with manual reset acc. to EN 60335-2-80, speed-controlled via a 5-step transformer or a stepless thyristor. Silent, long-life ball bearings. Terminal box (IP55) on the casing.

Mounting brackets included in delivery.

For indoor, outdoor installation as well as in wet areas.  
Air leakage class C acc. to EN 12237:2003.  
Installation in any mounting position.

PRODUCT: SYSTEMAIR  
TYPE: KV 100XL TW  
Item no. 1207