

K 200 M SILEO

Item no. 25366

Version: 50 Hz

Document type: **Product card**
 Document date: **2019-07-16**
 Generated by: **Systemair Online Catalogue**



Description

- Speed-controllable
- Quiet-running
- Increased efficiency
- Integral thermal contacts
- Can be installed in any position
- Can be installed outdoors
- Maintenance-free and reliable

The K Sileo series is designed for installation in ducts. All K-fans have a minimum 25 mm long spigot connections.

The fans have backward-curved blades and external rotor motors. To simplify the installation the K Sileo fan has a fixing bracket together with screws for mounting the bracket included as standard. The FK mounting clamp facilitates easy installation and removal, and prevents the transfer of vibration to the duct. The fans can be speed-controlled via a stepless thyristor or a 5-step transformer.

To protect the motor from overheating the fan has integral thermal contacts with manual reset.

The casing is manufactured from galvanised sheet steel and folded which gives the fan a close to air tight casing. Duct connected outdoor and wet room applications of the fan are possible due to the air tight casing. The K-fans have corrosion class C3.



Technical parameters

Nominal data		
Voltage	230	V
Frequency	50	Hz
Phase	1	~
Input power (P1)	102	W
Current	0,442	A
Max. airflow	0,211	m³/s
R.p.m.	2529	r.p.m.
Capacitor	2,5	µF
Weight	4,1	kg
Temperature data		
Max. temperature of transported air	70	°C
Max. temperature of transported air when speed-controlled	70	°C
Sound data		
Sound pressure level at 3 m	44,7	dB(A)

Protection / Classification

Insulation class	F
Enclosure class, motor	IP44

ErP

ErP ready	ErP 2016/ErP 2018
-----------	-------------------

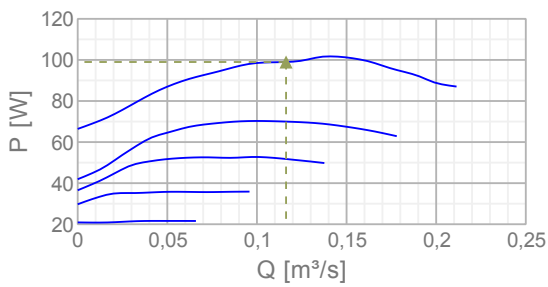
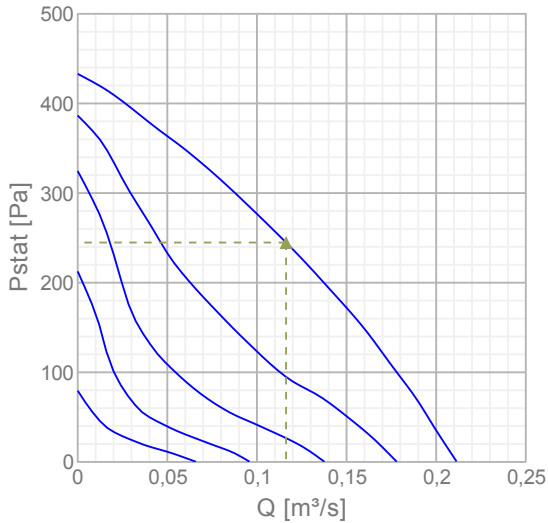
Diagrams**Diagrams****Max efficiency****Hydraulic data**

▲ Working air flow	0,116 m ³ /s
▲ Working static pressure	245 Pa
▲ Power	99 W
Speed	2530 r.p.m.
Current	0,435 A
SFP	0,851 W/(l/s)
Voltage	230 V

Sound power level		63	125	250	500	1k	2k	4k	8k	Tot
Inlet	dB(A)	41	62	62	64	63	62	57	50	70
Outlet	dB(A)	45	57	63	64	63	63	57	49	70
Surrounding	dB(A)	14	23	37	46	43	43	38	29	50

Dimensions

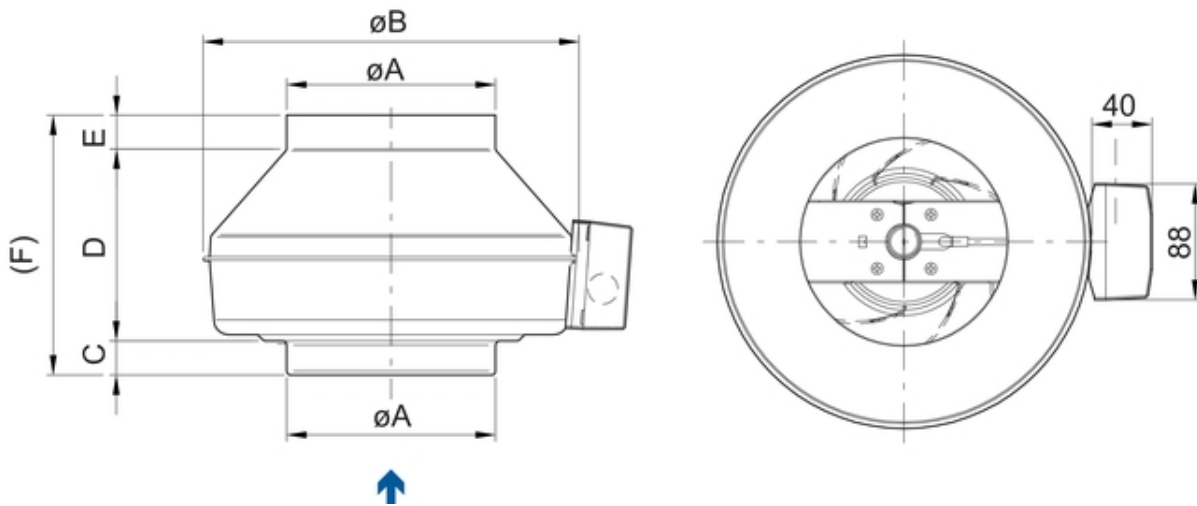

K	ϕA	ϕB	C	D	E	F
100 M	99	218	26	166	26	218
100 XL	99	246	26	161	26	213
125 M	124	218	27	142	27	196
125 XL	124	246	26	151	26	203
160 M	159	286	25	147	26	198
160 XL	159	336	29	166	26	221
200 M	199	336	30	148	27	205
200 L	199	336	30	174	27	231
250 M	249	336	30,5	119,5	27	177
250 L	249	336	30,5	144,5	27	202
315 M	314	408	32,5	160,5	27	220
315 L	314	408	38	161	27	225

Wiring

230V 1~

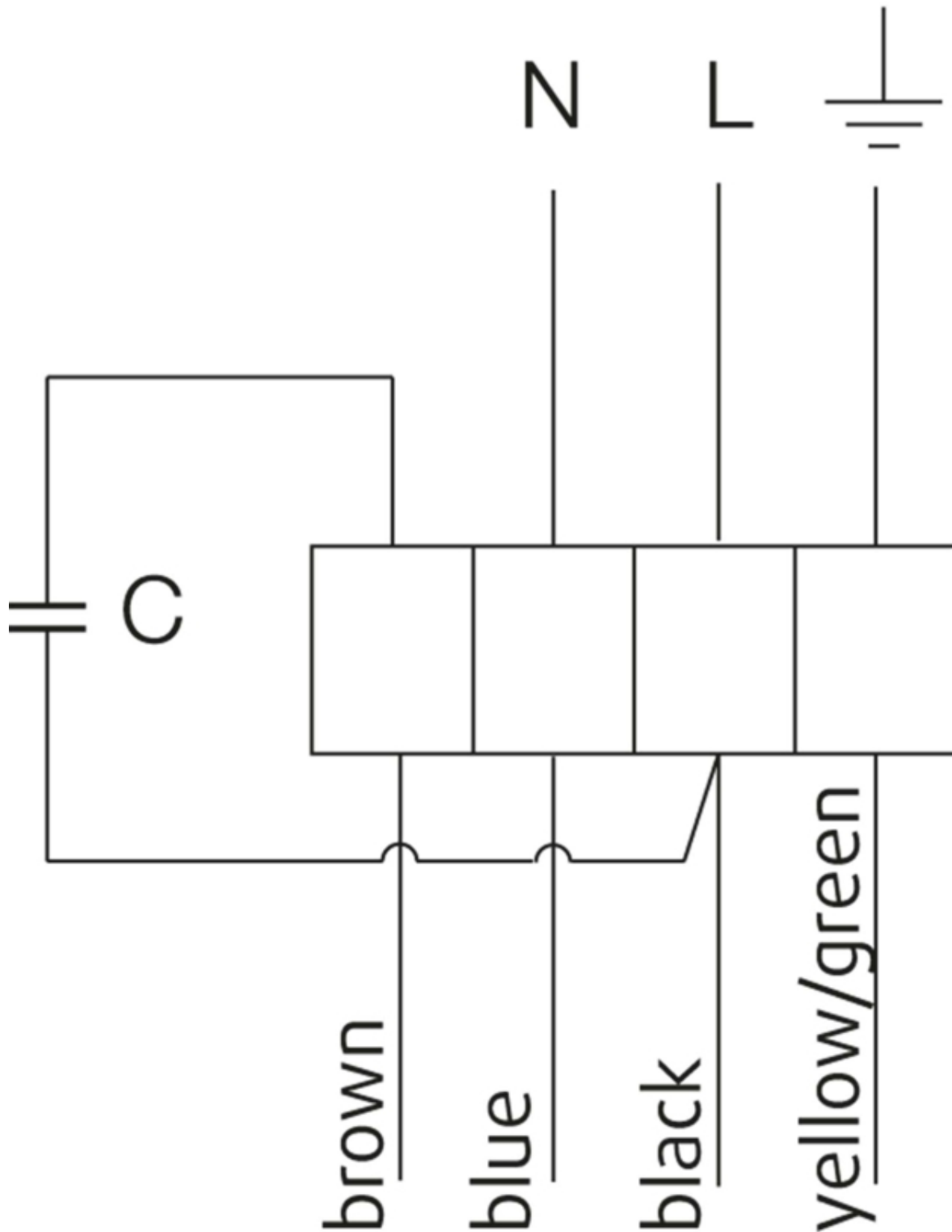

U1 = blue = blau

U2 = black = schwarz

Z = brown = braun

PE = yellow/green = grün-gelb

Accessories

Electric accessories

[RE 1.5 Speed control \(5000\)](#)
[REU 1.5 Speed control \(5004\)](#)
[REE 1 Speed control \(5314\)](#)
[REPT 6 Digital regulator \(5698\)](#)
[RT 0-30 Room Thermostat \(5151\)](#)
[CO2RT-R-D Transmitter \(6993\)](#)
[Presence detector/IR24-P \(6995\)](#)
[RETP 6 Temp/Pressure regulator \(32293\)](#)
[STL 1.5 Speed controller \(84251\)](#)
[REV-3POL/03 ON/OFF \(33978\)](#)
[FRQS-E-6A \(37419\)](#)
[FRQ5S-E-6A \(37421\)](#)
[DTV500A \(96807\)](#)

Accessories

[CB 200-3,0 230V/1 Duct heater \(5370\)](#)
[CB 200-2,1 230V/1 Duct heater \(5384\)](#)
[CBM 200-5,0 400V/2 Duct heater \(5483\)](#)
[VBF 200 Water heating battery \(1732\)](#)
[CWK 200-3-2,5 Duct cooler.circ \(30023\)](#)
[VBC 200-2 Water heating batt \(5459\)](#)
[LDC 200-600 Silencer \(5194\)](#)
[LDC 200-900 Silencer \(5195\)](#)
[FFR 200 Filter cassette \(1773\)](#)
[FGR 200 Filter cassette \(1812\)](#)
[FK 200 Fast clamp \(1611\)](#)
[VKK-200 Back draft damper \(1626\)](#)
[IGK-200 Wall Grid \(1633\)](#)
[RSK-200 Back draft damper \(5602\)](#)
[SG 200 Protection guard \(5609\)](#)
[VK-20 Louvre shutter \(5639\)](#)
[VBC 200-3 Water heatingq batt \(9841\)](#)
[LDC 200-300 Silencer \(53369\)](#)
[CB 200/S1/3,0KW 400V/2Duct hea \(5294\)](#)
[CB 200-5,0 400V/2 Duct heater \(5371\)](#)

Documentation

 [202341_Fans_Instructions_CE_A010.pdf \(1,83MB\)](#)

 [K fan mounting.wmv \(3,48MB\)](#)

Specification text

K 160XL Circular duct fan made of steel
DN 160, 230V/50Hz, 1~, imp. backw. curved

Centrifugal circular duct fan designed for easy and direct installation in ducts.
The casing is manufactured from galvanised sheet steel and airtight folded, air leakage class C acc. to EN 12237:2003
Circular connection spigot, length 25mm, acc. to EN1506:1997

Free-running, backward curved centrifugal impeller made of plastic.
Balancing made to G 6.3, motor compl. with impeller statically and dynamically balanced in two planes acc. to DIN ISO 1940 T.1.

Voltage controllable external rotor motor
(IP44), maintenance-free, the motor is placed inside the air flow for cooling. Integral thermal contacts with manual reset acc. to EN 60335-2-80,
speed-controlled via a 5-step transformer or a stepless thyristor. Silent, long-life ball bearings. Terminal box (IP55) on the casing

Mounting bracket included in delivery (unmounted).

For indoor, outdoor installation as well as in wet areas.

PRODUCT: SYSTEMAIR

TYPE: K 160XL

Item no. 1006