

MRH 900

Item no. 95754

Document type: **Product card**
 Document date: **2019-07-09**
 Generated by: **Systemair Online Catalogue**

Description

MRH roof hatch for smoke and heat extraction

- Vertical exhaust
- Tested to F400 (400°C/2h) requirement up to EN 12101-3
- SL 1000 (EN 12101-3)
- WL 1500 (EN 12101-2), wind suction load
- Certified as accessory of smoke and heat extract axial fans
- Insulation thickness: walls 120 mm ($k = 0,29 \text{ W/m}^2\text{K}$), cover 150 mm
- 24VDC electrically operated spindle actuator for cover opening
- Indication for opened/closed cover position (floating limit switches)
- Installation on flat or inclined roof - adjustable side bars to roof pitch (possibility to adjust depends on the height position of side bar - instructions)
- Installation on flat surface (e.g. concrete) or through the roof
- Robust structure
- Sucking side connection acc. Eurovent 1/2
- Exhaust protective grid is included

MRH, motorised roof hatch is used in case of fire to extract smoke gases from the room. Smoke-free escape ways increase the chances to rescue people in case of fire.

MRH is intended for insertion of axial smoke and heat extract fan with motor inside air stream. **In serially available version the hatch is intended for emergency use only (without EMC protection).** Tested also to Re 10000 (cycles open -close), but **for dual use additional safety elements are needed to reduce risk due to hatch closing.** For installation on the top of buildings up to snow load SL 1000 and wind suction load WL 1500. The casing is made as a double metal layer with mineral wool insulation. The hatch casing is made of pre-galvanised steel while the hatch cover of AlMg3. Service switches of motor and actuator serially on the hatch casing. Electrical connection in the service switches. When choosing AES exhaust air and smoke extraction control accessory, please observe serial connecting capability of the service switch of the fan (instructions). Higher connecting capability on request.

Recommended start of the fan is 20s after starting actuator for cover opening, to ensure vertical exhaust of hot gases. For non-ducted appliance protective grid for inlet is available as accessory.



Technical parameters

Other

Weight

303 kg

Dimensions

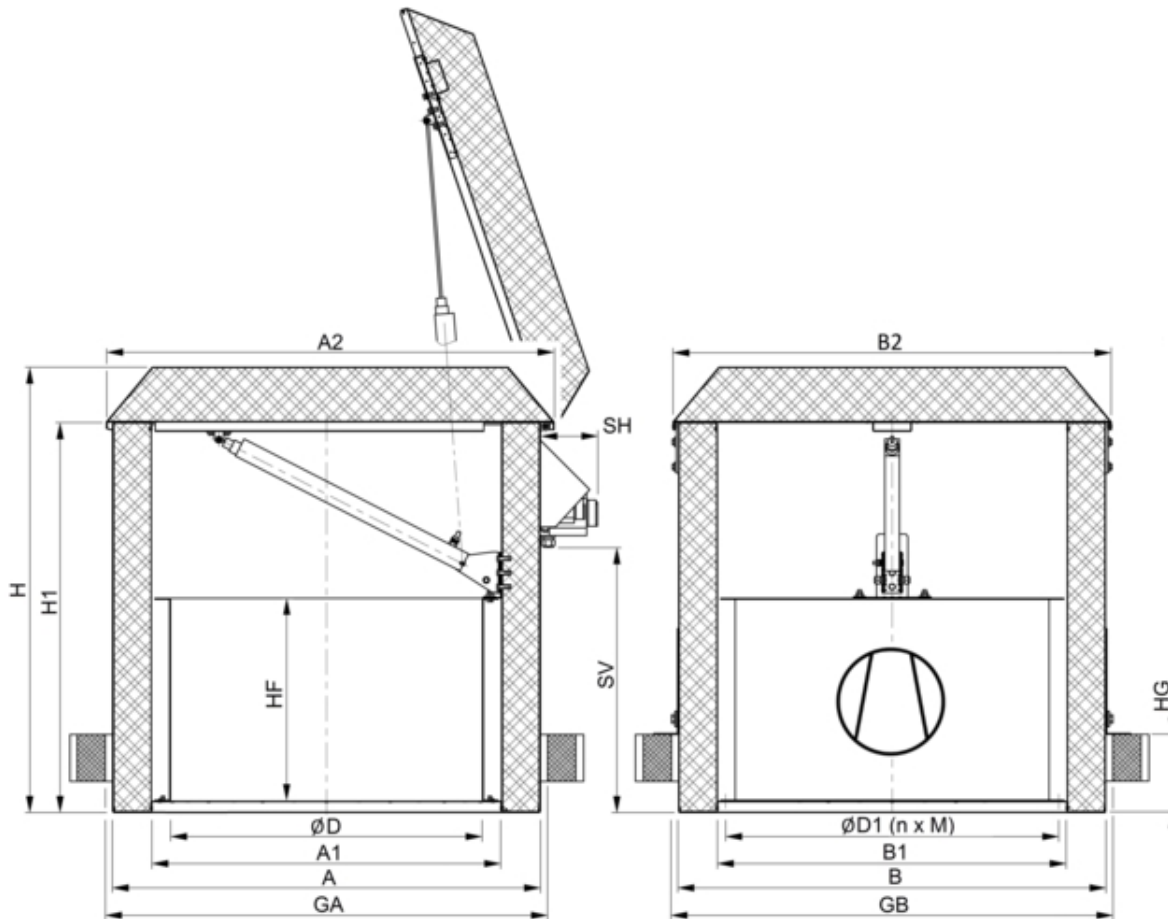

	øD	øD1	n x M	A	A1	A2	B	B1	B2	GA	GB	HF	H1	H	SH, ~	SV, ~	HG***
MRH 900	900	970	16 x M8**	1380	1124	1440	1380	1124	1410	1420	1420	700	1250	1410	185	850	0, 250, 500
* bolts /** nuts																	
***HG = 0 (lowest position of side bars) - alfa (pitch angle) = 0 - 9°; HG = 250 (middle position) - alfa = 0 - 9°; HG = 500 (upper position) - alfa = 0 - 2° or 14 - 21°																	
The side bars can be upon request ordered to meet specific roof pitch. More about side bar setting see instructions. MRH centreline deviation to vertical max. +/- 5°.																	

Accessories

Accessories

- [ESD-F 900 inlet cone AXC \(305265\)](#)
- [SG AXC/AM/AR 900 guard grill \(310694\)](#)
- [EVH 900 flex.conn. AXC 400°C \(8373\)](#)
- [GFL-AR/AXC 900 counter flange \(8385\)](#)

Documentation

 [IMO_MRH_en_31_07_2018.pdf \(3,12MB\)](#)

 [Certif_DVV_XS_XL_DVAX_DVG_BKF_2015_0086_CPR_597958.pdf \(719,51kB\)](#)

 [MRH_900_01.dxf \(766,95kB\)](#)

 [DVAX_MRH_E8307_17_01_2017.pdf \(3,22MB\)](#)

Wiring

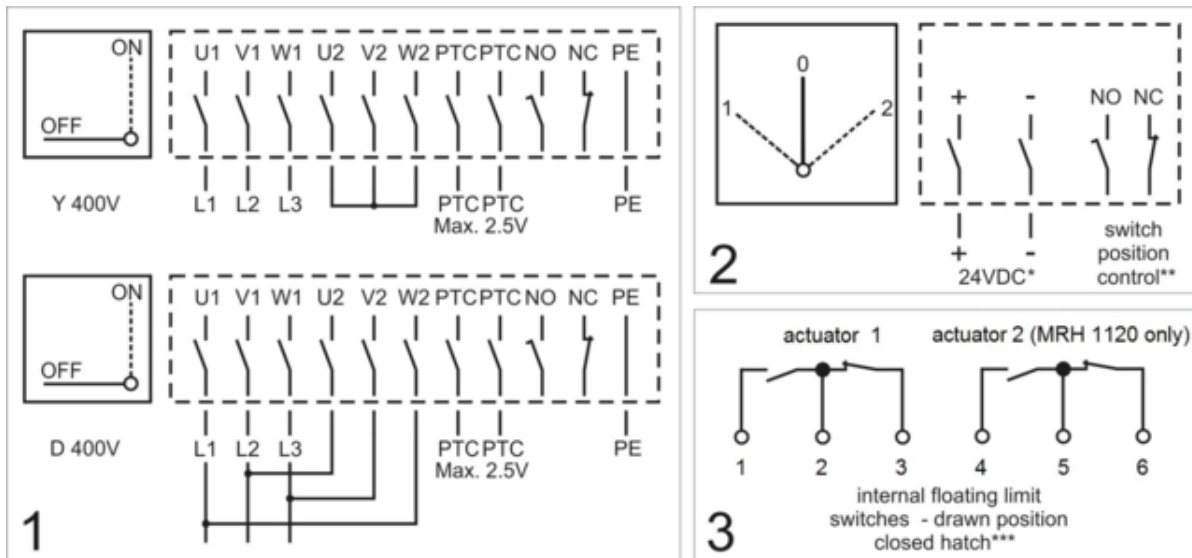

Diagram 1 (connection of electric motor in the fan's service switch)

Electric motor with $P2 \geq 5,5$ kW with star-delta starting

In Y starting only, in D operation only

Lock the switch in position ON to prevent unintended switch OFF (lock is not in scope of delivery)

Diagram 2 (connection of actuator in the actuator's service switch)

* 24VDC (+30/-20%)

** NO/NC are intended to control position of actuator's service switch (ON - OFF)

Warning: the control voltage 24VDC to open or close hatch cover should apply max. 6 minutes.

This is to ensure by control system (use actuator's internal floating limit switches as indication of cover position to cut off the control voltage). More see instructions (current)

The connection cable to service switch calculate with max. 1V voltage drop at max. load!

Operating mode for peak load at 25°C ambient: S2 1 min

Operating mode for continuous load at 40°C ambient: S3 5% (example: open in 30s, then wait 9min 30s)

Max. current of actuator(s) at SL 1000 (rated MRH load):

MRH 400-630: 4A

MRH 710-800: 6A

MRH 1000: 8A

MRH 1120: 2x8A=16A

Diagram 3 (connection of actuator's internal floating limit switches in the actuator's service switch)

*** drawn position - closed hatch

1-2 opened, 2-3 closed in closed hatch position

1-2 closed, 2-3 opened in opened hatch position

1-2 closed, 2-3 closed in any intermediary position of the hatch cover

1-2, 4-5 opened, 2-3, 5-6 closed in closed hatch position (MRH 1120 only)

1-2, 4-5 closed, 2-3, 5-6 opened in opened hatch position (MRH 1120 only)

1-2, 4-5 closed, 2-3, 5-6 closed in any intermediary position of the hatch cover (MRH 1120 only)

Potentialfree NC contacts, load capacity 24VDC/1A

Functions of the actuator's service switch:

Position 0: stop (NO - opened contact, NC - closed contact) - SAFETY POSITION

Position 1: open hatch cover (NO - closed contact, NC - opened contact) - WARNING!

Position 2: close hatch cover (NO - opened contact NC - closed contact) - DANGER!

Specification text

MRH, motorised hatch roof unit is intended for insertion of axial smoke and heat extract fan with motor inside air stream. Tested for extraction of hot gases up to 400°C for 2h (F400). Certified accessory of smoke and heat exhaust fans, in serial version for emergency use only. The hatch opens with actuator. Vertical extraction in case of fire. For installation on the top of buildings up to snow load SL 1000 and wind suction load WL 1500.

Installation on flat or inclined roof (surface or through the roof mounting). The casing is made as a double metal layer with mineral wool insulation (wall thickness: 120 mm, cover thickness: 150 mm). The hatch casing is made of pre-galvanised steel, the hatch cover but of AlMg3. Service switches of motor and actuator serially on the hatch casing. Electrical connection in the service switches. Recommended start of the fan is 20s after starting actuator for cover opening, to ensure vertical exhaust of hot gases. Sucking side connection acc. Eurovent ½. Exhaust protective grid included.