

## PREHEAT. KIT TOPVEX CB400 EL

Item no. 131041

Document type: **Product card**

Document date: **2019-07-02**

Generated by: **Systemair Online Catalogue**

### Description

A pre-heater is available as an accessory for Systemair Topvex units with counter flow heat exchanger. The pre-heater will compensate the lack of reheater capacity during bypass de-icing.

The pre-heater is connected to the Topvex Corrigo control and will be engaged only (default\*) during bypass defrosting mode, to secure supply temperature. Depending of air flow and heating coil capacity the set point for the pre-heater can be set and optimized from the Corrigo control. (Set point is determined according to lack of reheater capacity during bypass de-icing.)

\*(optional function settings can be selected from Corrigo menu. In example, conditioned outdoor air temperature)

The kit contains of 1 expansion module, 1 pre-heater, 1 outdoor air sensor and 1 instruction.



### Technical parameters

Rating data	
Voltage	400 V
Phase	3 ~
Power	12 kW
Current	17,3 A
Weight	7 kg

### Heating capacity

#### Dimensions

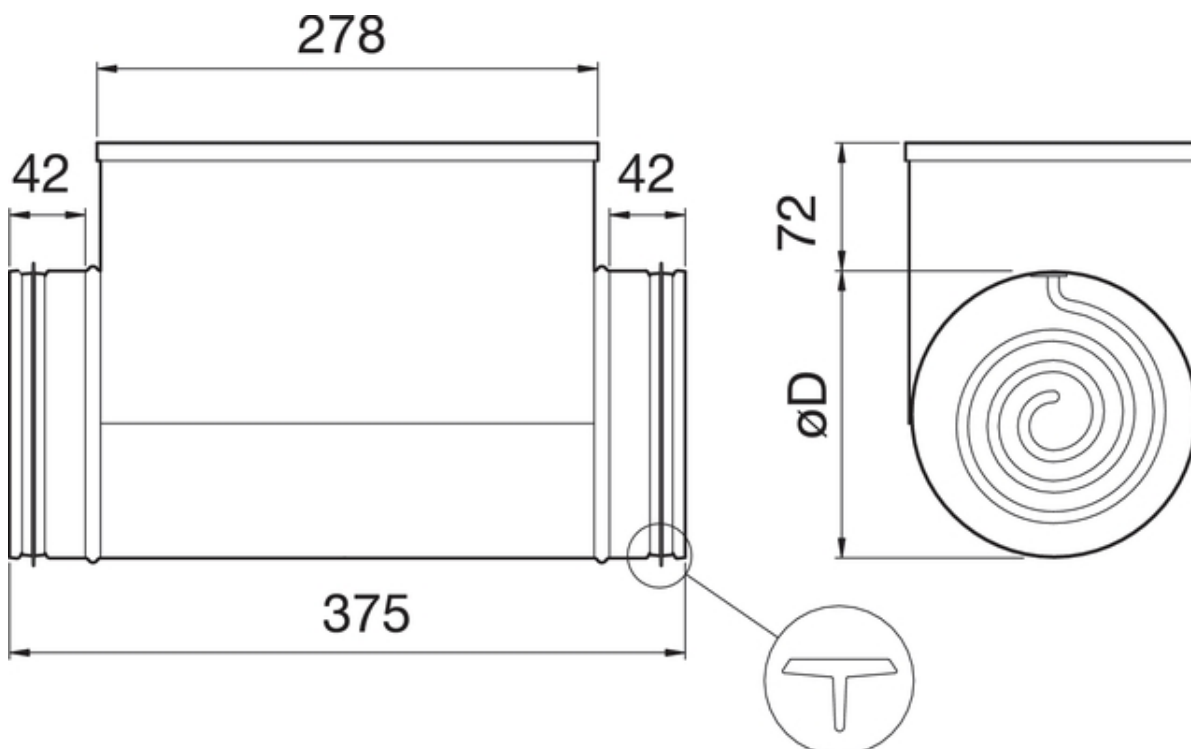

ø D = 400 mm

## Accessories

## Documentation



CB-MQXL 173046-01\_IMO.pdf (338,52kB)



Pre\_heater\_installation\_counter\_flow\_134351\_EN\_A003.pdf (3,24MB)