

RBM 40-20/9 400V/3 DUCT HEATER

Item no. 5450

Document type: **Product card**
 Document date: **2019-06-25**
 Generated by: **Systemair Online Catalogue**

Description

Duct heater with integral control equipment

Duct heater for rectangular ducts. Manufactured from Aluzincoated sheet steel with a heating element in stainless steel. The heater has integral overheating protection with a manual reset function. The heater is controlled by an integral electronic temperature regulator, using so-called time-proportional Pulse/Pause technology. This provides extremely precise temperature control. As a thyristor is used for adjusting the temperature, the unit has no moving parts. This means that it is silent and not susceptible to wear and tear. The RBM is supplied with a complete and fully-connected control system including contactors and alarm relays. This minimises the installation cost. The external installation requirements are: mains power supply, control circuit, dial for setting required temperature, sensor and a possible alarm circuit. The minimum air volume is based on a minimum air velocity of 1.5 m/s. These duct heaters are designed for a maximum output air temperature of 40°C.



Technical parameters

Power	9	kW
Voltage	400V 3~	V
Current	13	A
Min. airflow	0,125	m³/s
Weight	10,7	kg

Accessories

Electric accessories

- [TG-K330 Duct Sensor 0-30°C \(5160\)](#)
- [TG-R430 Room sensor 0-30°C \(5162\)](#)
- [TG-R530 Room sensor 0-30°C \(5163\)](#)
- [TG-R630 External sensor \(5164\)](#)
- [DTV200 \(6261\)](#)

Dimensions

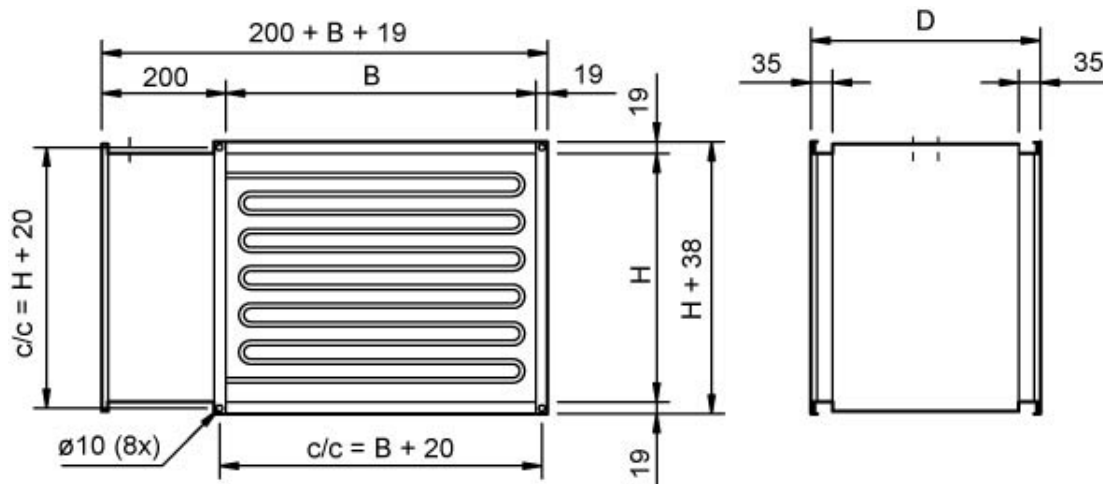

	B	H	D
RBM 40-20/9	400	200	500
RBM 50-25/15	500	250	500
RBM 50-30/15	500	300	500
RBM 60-30/27	600	300	500
RBM 60-35/27	600	350	500
RBM 70-40/27	700	400	500

Wiring

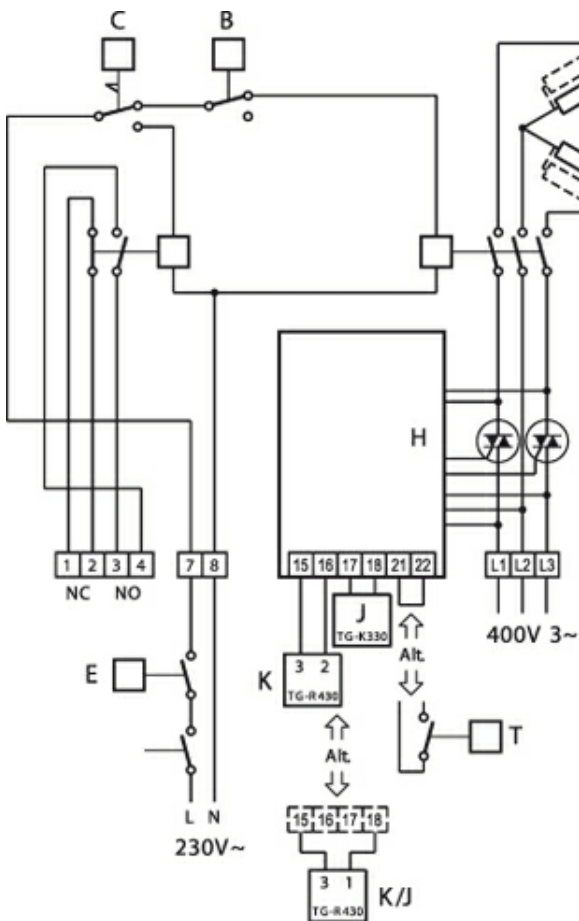

- A = Heating elements
- B = Over heat protection with automatic reset
- C = Over heat protection with manual reset
- E = Interlocking
- H = Thyristor
- J = Sensor
- K = Set value adjustment
- K/J = Combined room sensor and set value adjustment
- T = Air flow switch/Pressure switch

Documentation

 RB RBM RBK IMO.pdf (102,09kB)

 Conformity decl. RB RBM RBK 021024.pdf (32,12kB)

Heating capacity