

## RB 50-30/15-1 400V/3 DUCT HEAT

Item no. 9635

Document type: **Product card**

Document date: **2019-06-25**

Generated by: **Systemair Online Catalogue**

### Description

Duct heater for rectangular ducts. Manufactured from Aluzinc-coated sheet steel with a heating element in stainless steel. The heater has integral overheating protection with a manual reset function. Suitable for control by room thermostat or TTC. The minimum air volume is based on a minimum air velocity of 1.5 m/s. These duct heaters are designed for a maximum output air temperature of 40°C.



### Technical parameters

Power	15	kW
Voltage	400 3~	V
Current	22	A
Min. airflow	0,236	m³/s
Weight	13,8	kg

### Accessories

#### Electric accessories

[TG-K330 Duct Sensor 0-30°C \(5160\)](#)

[TG-R430 Room sensor 0-30°C \(5162\)](#)

[TG-R530 Room sensor 0-30°C \(5163\)](#)

[TG-R630 External sensor \(5164\)](#)

[TTC-2000 Temp. control 25A \(5171\)](#)

[DTV500A \(96807\)](#)

## Dimensions

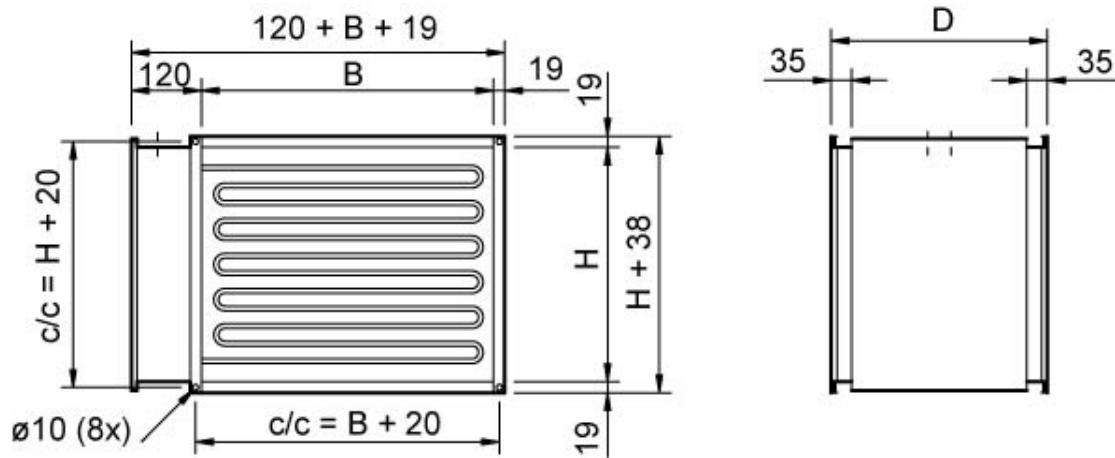

	B	H	D
RB 40-20/9-1	400	200	370
RB 40-20/15-1	400	200	500
RB 50-25/15-1	500	250	370
RB 50-25/22-2	500	250	500
RB 50-30/15-1	500	300	370
RB 50-30/27-2	500	300	500
RB 60-30/22-2	600	300	500
RB 60-30/34-2	600	300	500
RB 60-35/27-2	600	350	370
RB 60-35/45-3	600	350	500
RB 70-40/27-2	700	400	370
RB 70-40/45-3	700	400	370
RB 80-50/45-3	800	500	370
RB 80-50/68-4	800	500	370
RB 80-50/68-4	1000	500	370
RB 100-50/68-4	1000	500	370
RB 100-50/80-5	1000	500	370

## Wiring

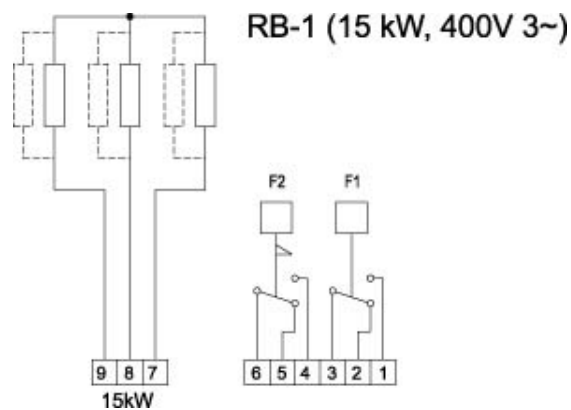

F1 = Overheating protection, automatic (60°C)

F2 = Overheating protection, manual (120°C)

## Documentation

 [RB RBM RBK IMO.pdf \(102,09kB\)](#)

 [Conformity decl. RB RBM RBK 021024.pdf \(32,12kB\)](#)

## Heating capacity