

## REU 1.5 SPEED CONTROL

Item no. 5004

Document type: **Product card**

Document date: **2019-06-25**

Generated by: **Systemair Online Catalogue**

### Description

Manual five-step transformer

A single-phase transformer which controls the fan speed by altering the supply voltage in five fixed steps. The steps are adjusted manually, using the control knob on the front of the unit. There are two control switches: one for higher fan speeds and one for lower fan speeds. Switching between the high and low settings is done by an external change-over contact, which could be a thermostat or a timer. The indicator lamp on the front shows when the transformer is in operation. The fuse may be reset from outside. The REU has a self-extinguishing thermoplastic casing. Supply voltage: 230V 50/60Hz.

NOTE! Fans with external thermal contact leads (TK) must always be connected to a motor protection device.



### Technical parameters

Voltage	230	V
Phase	1	~
Frequency	50/60	Hz
Current	1,5	A
Enclosure class	54	
Recommended fuse	1,8	A
Width	105	mm
Height	200	mm
Depth	105	mm
Weight	1,8	kg

## Accessories

## Dimensions

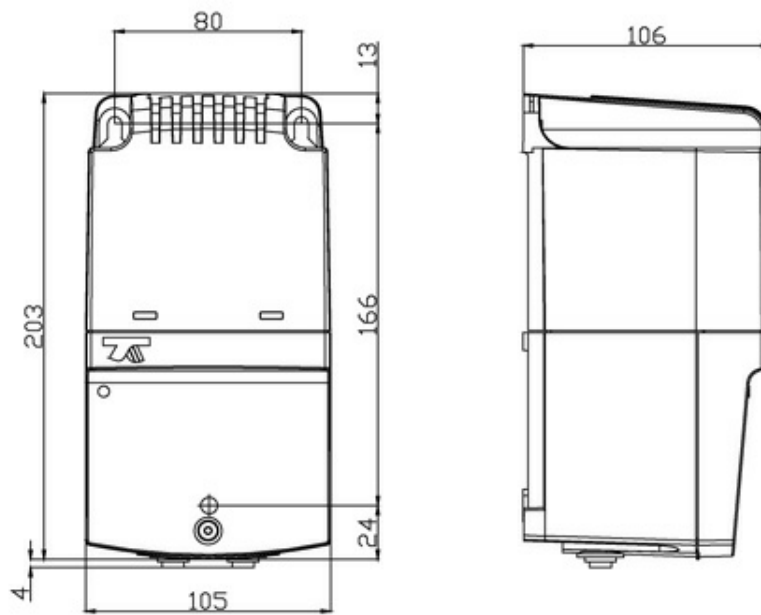

## Wiring

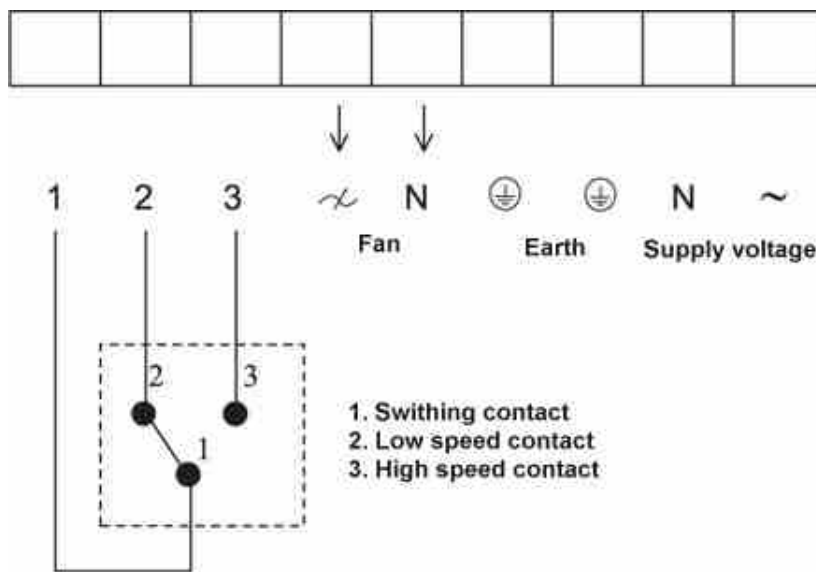

**NB** A switching contact has to be connected

## Documentation

 RE\_RTRE\_REU\_IMO\_GB.pdf (245,21kB)

 Declaration Of Conformity\_RE\_REU\_RTRE\_EN-2017.pdf (26,64kB)

## Specification text