

TFSK 200 RED

Item no. 1372

Version: 50 Hz

Document type: **Product card**
 Document date: **2019-06-05**
 Generated by: **Systemair Online Catalogue**



Description

- Swing-out
- Speed-controllable
- Easy to install
- Reliable

The TFSK range consists of roof fans with square connection and are fitted with a single-inlet centrifugal fan with backward-curved blades and external rotor motors. The motors can be tilted outwards to facilitate inspection and service. They have integral on/off switch and are supplied with 1 m cable and are easy connected to our standard roof curbs TG, FDS and SSD.

These fans are suitable for exhaust-air ventilation systems, e.g. single and multiple dwellings, offices and day nurseries. To protect the motors from overheating, all motors have an integral thermal contact with automatic reset. The fans are manufactured in powder-coated, galvanized sheet steel and are delivered in the standard colours of black or brick red.



Technical parameters

Nominal data		
Voltage	230	V
Frequency	50	Hz
Phase	1	~
Input power (P1)	108	W
Current	0,466	A
Max. airflow	0,208	m³/s
R.p.m.	2537	r.p.m.
Capacitor	3	µF
Weight	4,2	kg
Temperature data		
Max. temperature of transported air	62	°C
Max. temperature of transported air when speed-controlled	62	°C
Sound data		
Sound pressure level at 10 m	40,2	dB(A)
Protection / Classification		
Insulation class	B	
Enclosure class, motor	IP44	

ErP

ErP ready

ErP 2016/ErP 2018

Energy class, basic unit

E

Energy class, basic unit option

B

Energy class label

Energy class, basic unit

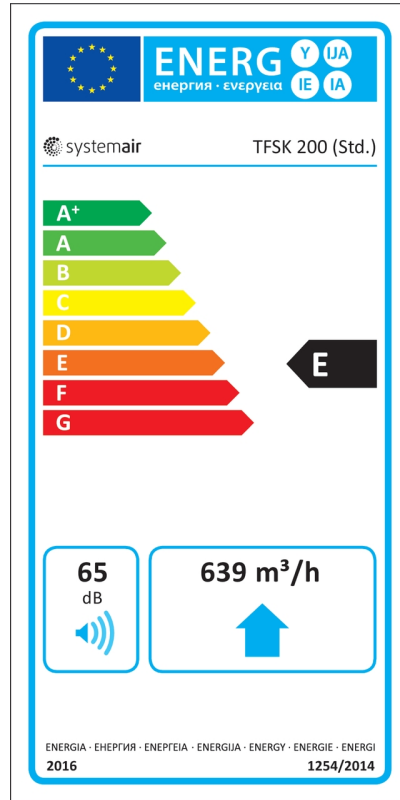

Energy class, unit with local demand control

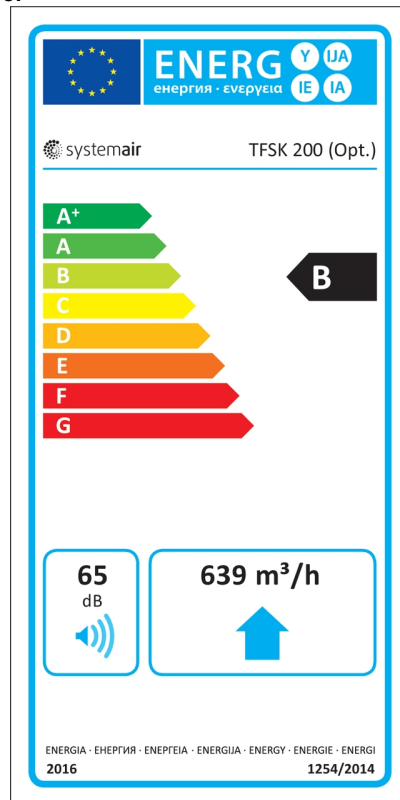

Diagrams

Diagrams

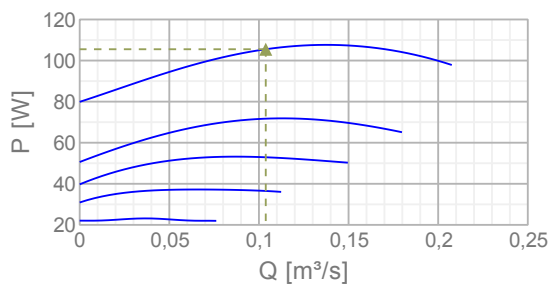
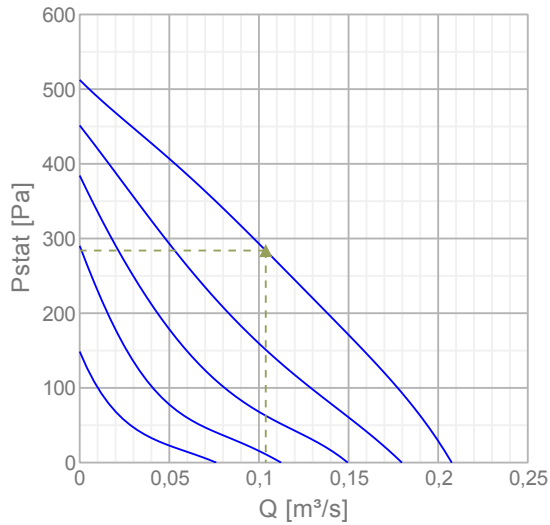

Max efficiency

Hydraulic data										
▲ Working air flow										0,104 m ³ /s
▲ Working static pressure										284 Pa
▲ Power										106 W
Speed										2556 r.p.m.
Current										0,458 A
SFP										1,02 W/(l/s)
Voltage										230 V
Sound power level		63	125	250	500	1k	2k	4k	8k	Tot
Inlet	dB(A)	50	62	64	64	66	63	56	47	71
Outlet	dB(A)	31	52	56	61	67	67	61	49	71

Dimensions

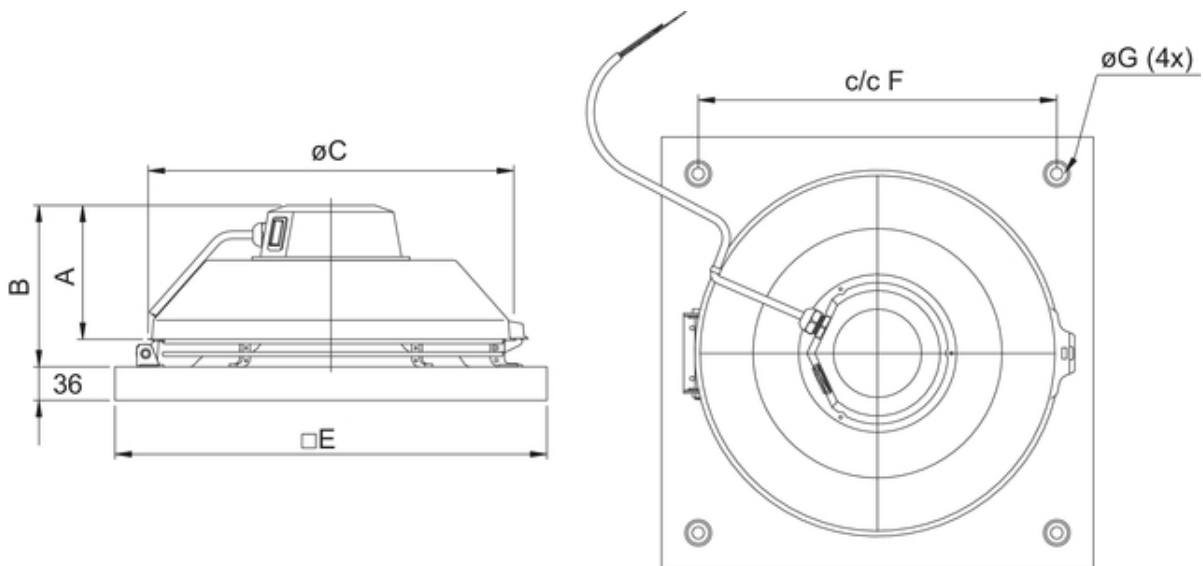

TFSK	A	B	øC	□E	c/c F	øG
200	123	160	364	421	330	9

Accessories

Electric accessories

[RE 1.5 Speed control \(5000\)](#)
[REU 1.5 Speed control \(5004\)](#)
[REE 1 Speed control \(5314\)](#)
[REPT 6 Digital regulator \(5698\)](#)
[RT 0-30 Room Thermostat \(5151\)](#)
[CO2RT-R-D Transmitter \(6993\)](#)
[Presence detector/IR24-P \(6995\)](#)
[F251-16-60 Cookerhood transf \(5931\)](#)
[DTV200 \(6261\)](#)
[STL 1.5 Speed controller \(84251\)](#)
[MicroREX D21 Plus Time Switch \(17822\)](#)
[DTV500A \(96807\)](#)

Accessories

[LDC 200-600 Silencer \(5194\)](#)
[LDC 200-900 Silencer \(5195\)](#)
[TG 400-800 Roof curb \(1718\)](#)
[STG Connectionp.200 TG400-800 \(1765\)](#)
[BTG 400 Back Draft Damper \(5092\)](#)
[RSK-200 Back draft damper \(5602\)](#)
[VKS 310/311 Back draft damper \(9543\)](#)
[FDS 310/311 flat roof socket \(9549\)](#)
[VKM 310/311 Back draft damper \(9555\)](#)
[SSD 310/311 socket silencer \(9561\)](#)
[ASF 310/311 inlet flange DVS \(9568\)](#)
[ASS 310/311 flex. inl.con. DVS \(9575\)](#)
[ASK 310/311 inflow box SSD \(300904\)](#)
[TDA DV 310/311 Adapter \(301392\)](#)
[LDC 200-300 Silencer \(53369\)](#)
[FDS-L 310/311 flat roof socket \(95279\)](#)

Documentation

 [202341_Fans_Instructions_CE_A010.pdf \(1,83MB\)](#)

 [Certificate S-mark TFSK_R 1309486_EN.pdf \(1,77MB\)](#)

Specification text