

TFSR 160 SILEO GREY

Item no. 92014

Version: 50 Hz

Document type: **Product card**
 Document date: **2019-06-05**
 Generated by: **Systemair Online Catalogue**



Description

- Swing-out
- Speed-controllable
- Easy to install
- Reliable

The TFSR range consists of roof fans with circular connection and are fitted with a single-inlet centrifugal fan with backward-curved blades and external rotor motors. The motors can be tilted outwards to facilitate inspection and service. They have integral on/off switch and are supplied with 1 m cable for fast connection to the mains e.g. via the connection box on the roof curb TOB or TOS.

These fans are suitable for exhaust-air ventilation systems, e.g. single and multiple dwellings, offices and day nurseries. To protect the motors from overheating, all motors have an integral thermal contact with automatic reset. The fans are manufactured in powder-coated, galvanized sheet steel and are delivered in the standard colours of black or brick red.

TFSR is delivered with a spigot connection if the installation requires direct duct connection. TFSR 125-160 are delivered with a Ø 160 spigot and TFSR 200-315 with a Ø 200. The spigot is not pre-assembled to the fan.



Technical parameters

Nominal data		
Voltage	230	V
Frequency	50	Hz
Phase	1	~
Input power (P1)	50,4	W
Current	0,221	A
Max. airflow	0,12	m³/s
R.p.m.	2393	r.p.m.
Capacitor	1,5	µF
Weight	3,3	kg
Temperature data		
Max. temperature of transported air	70	°C
Max. temperature of transported air when speed-controlled	70	°C
Sound data		
Sound pressure level at 4 m	40,9	dB(A)
Sound pressure level at 10 m	32,9	dB(A)

Protection / Classification	
Insulation class	B
Enclosure class, motor	IP44
ErP	
ErP ready	ErP 2018
Energy class, basic unit	E
Energy class, basic unit option	B

Energy class label

Energy class, basic unit

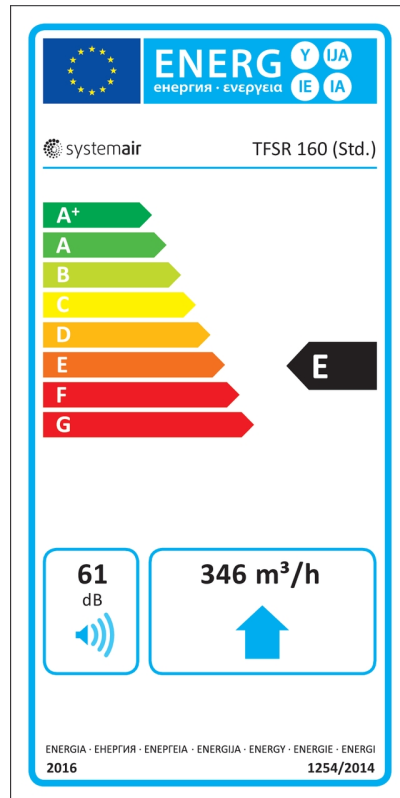

Energy class, unit with local demand control

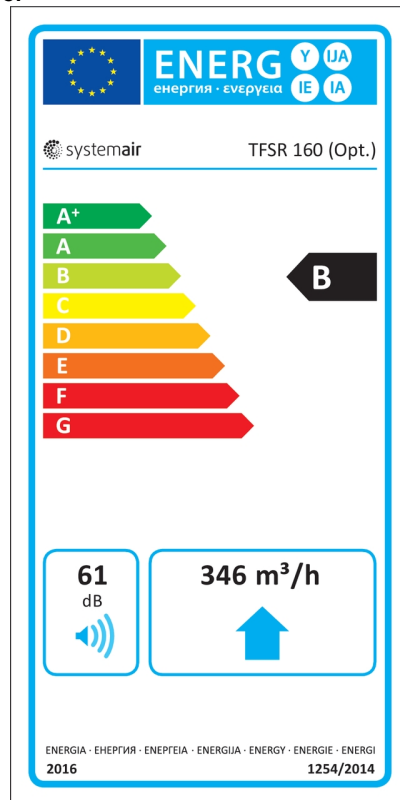

Diagrams

Diagrams

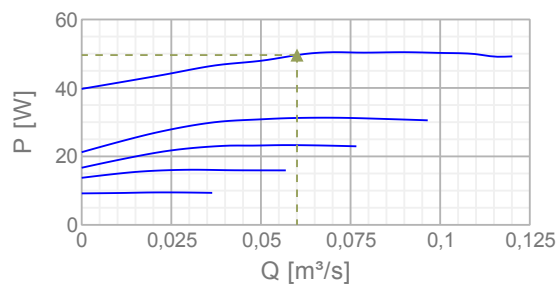
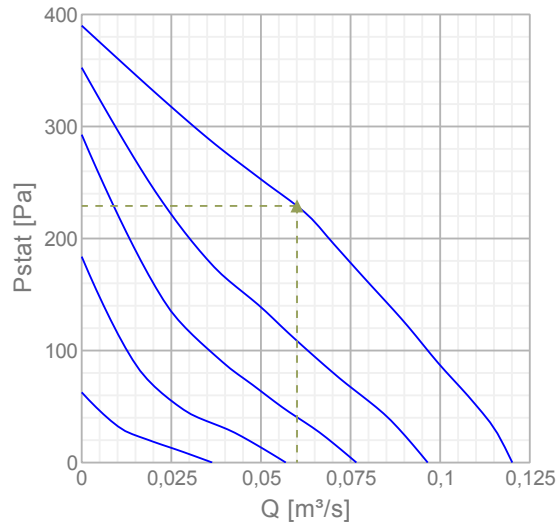

Max efficiency

Hydraulic data											
▲ Working air flow										0,0601 m³/s	
▲ Working static pressure										229 Pa	
▲ Power										49,6 W	
Speed										2427 r.p.m.	
Current										0,217 A	
SFP										0,826 W/(l/s)	
Voltage										230 V	
Sound power level			63	125	250	500	1k	2k	4k	8k	Tot
Inlet	dB(A)		29	39	46	54	58	56	54	49	62
Outlet	dB(A)		29	39	46	55	59	59	56	50	64

Dimensions

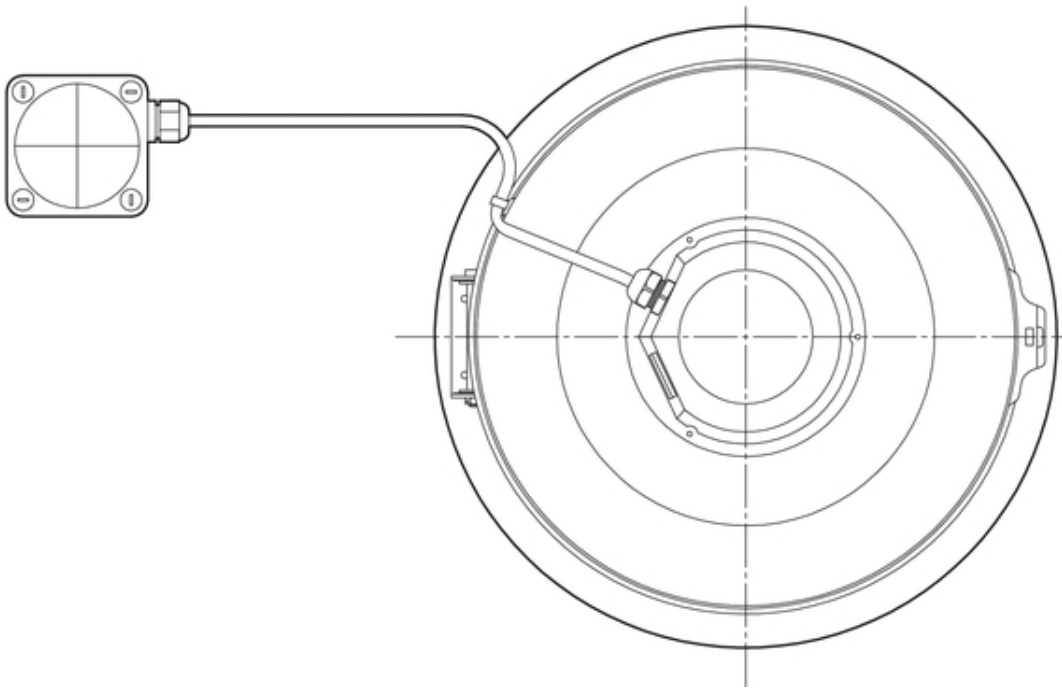
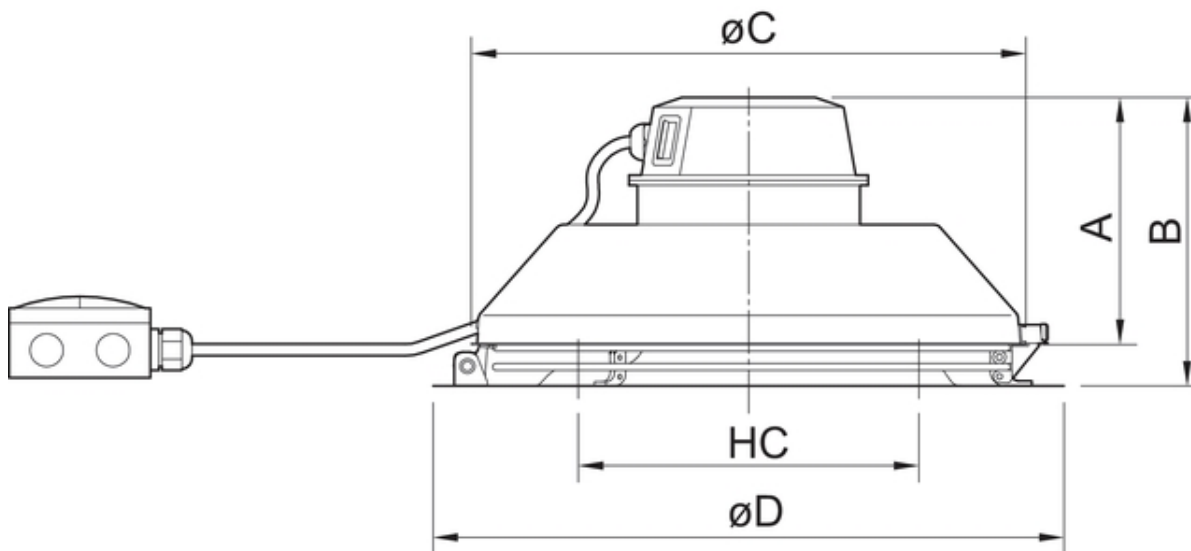

TF SR	A	B	$\varnothing C$	$\varnothing D$	HC
160	120	145	334	380	205

Wiring

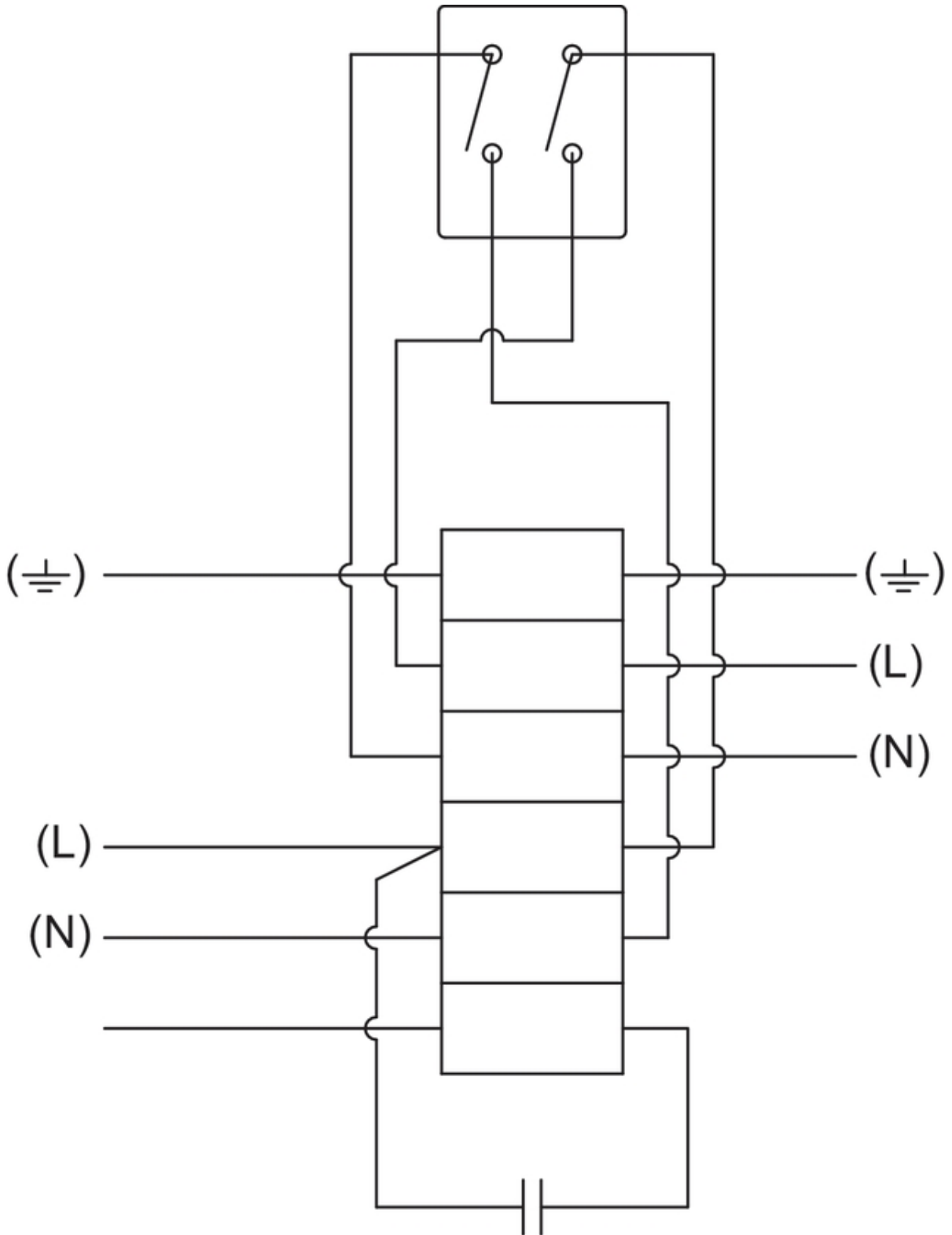

Accessories

Electric accessories

[RE 1.5 Speed control \(5000\)](#)

[REU 1.5 Speed control \(5004\)](#)

[REE 1 Speed control \(5314\)](#)

[REPT 6 Digital regulator \(5698\)](#)

[RT 0-30 Room Thermostat \(5151\)](#)

[CO2RT-R-D Transmitter \(6993\)](#)

[Presence detector/IR24-P \(6995\)](#)

[RETP 6 Temp/Pressure regulator \(32293\)](#)

[DTV200 \(6261\)](#)

[STL 1.5 Speed controller \(84251\)](#)

[MicroREX D21 Plus Time Switch \(17822\)](#)

[DTV500A \(96807\)](#)

Accessories

[LDC 160-600 Silencer \(5192\)](#)

[LDC 160-900 Silencer \(5193\)](#)

[RSK-160 Back draft damper \(5601\)](#)

Documentation



[202341_Fans_Instructions_CE_A010.pdf \(1,83MB\)](#)



[TFSR mounting instruction_205504 _A001.pdf \(286,94kB\)](#)



[Certificate S-mark TFSK_R 1309486_EN.pdf \(1,77MB\)](#)