

## UGS 042/500 ADAPTER FLEX.

Item no. 4357

Document type: **Product card**  
Document date: **2019-05-21**  
Generated by: **Systemair Online Catalogue**

### Description

Adaptor flexible square to circular

Reduction from square to round. The frame is manufactured from aluminium and neoprene coated fabric. For temperature up to 60°C. The circular side has a locking ring for easy installation to the duct system.

Suitable for MUB and K.. airhandling units.

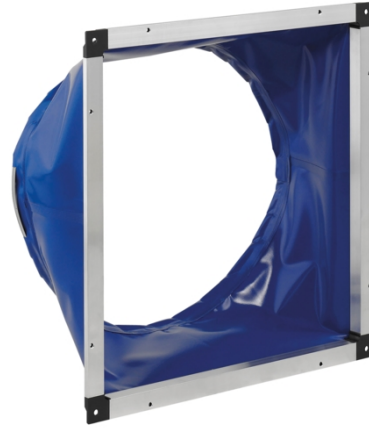

### Technical parameters

#### Other

Weight

1,5 kg

## Dimensions

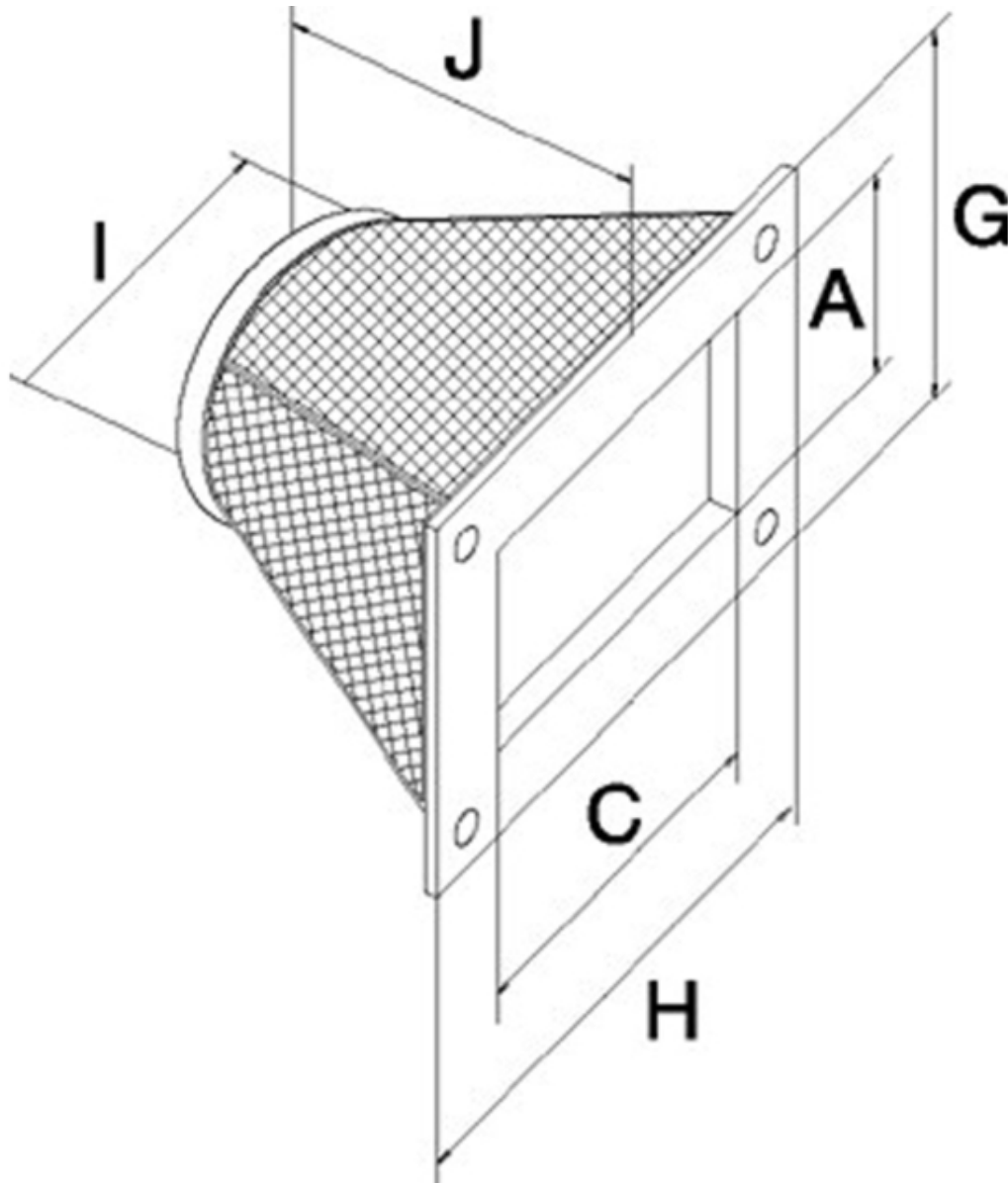

| A/C         | G/H     | I   | J   |
|-------------|---------|-----|-----|
| UGS 042/500 | 528 588 | 500 | 210 |

## Accessories

## Documentation