

# VKM 560/630 BACK DRAFT DAMPER

Item no. **9557**

Document type: **Product card**  
 Document date: **2019-05-15**  
 Generated by: **Systemair Online Catalogue**

## Description

VKM motor driven shutter

Consists of flanges manufactured from galvanized steel, and of shutter blades manufactured from seawater resistant aluminium.  
 Is equipped with a servo motor (230V/50Hz/25W), which can be operated manually as well as through the automatic controllers of the air conditioning unit. While the motor is energized the shutter stays open. When separated from the supply the shutter will close automatically.  
 Temperature approx 70°C.

Suitable for DVS/DHS, DVSI, DVN.



## Technical parameters

Other		
Weight	8,9	kg
Default group		
Voltage	230	V
Phase	1	~
Frequency	50	Hz
Enclosure class, motor	IP43	

Dimensions

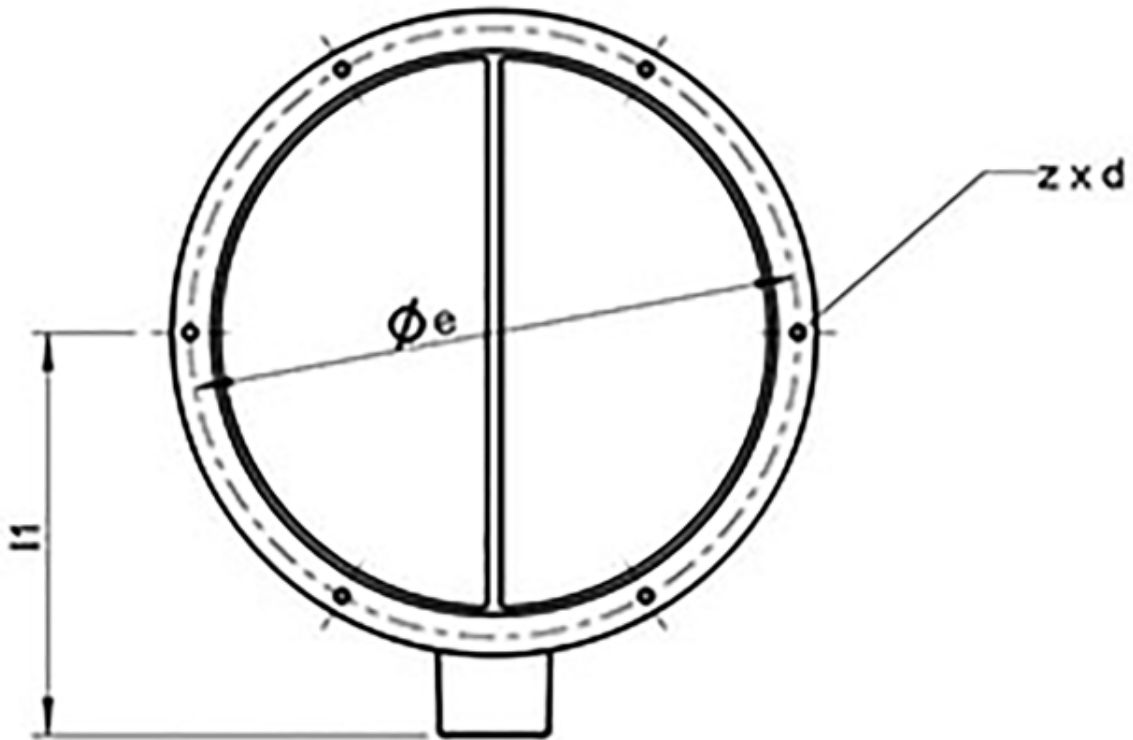
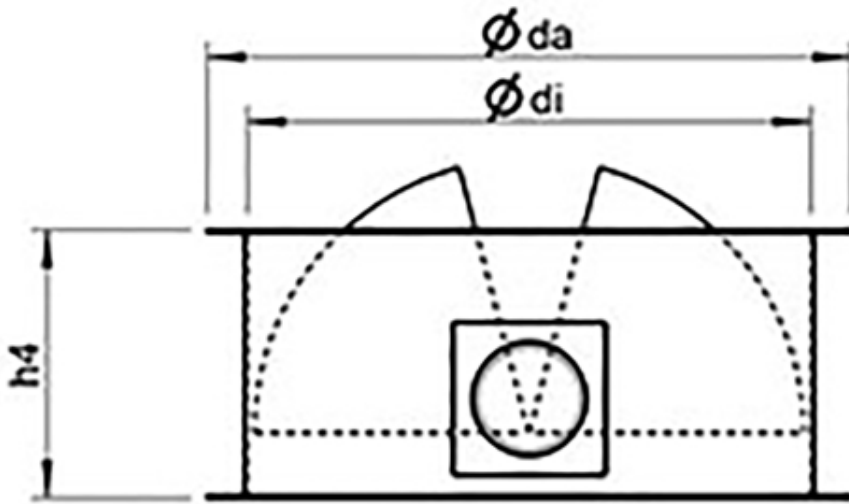

	$\varnothing da$	$\varnothing e$	$\varnothing di$	$h4$	$l1$	$z \times d$
VKM 560/630	639	605	573	255	375	8 x $\varnothing 10$

Diagram

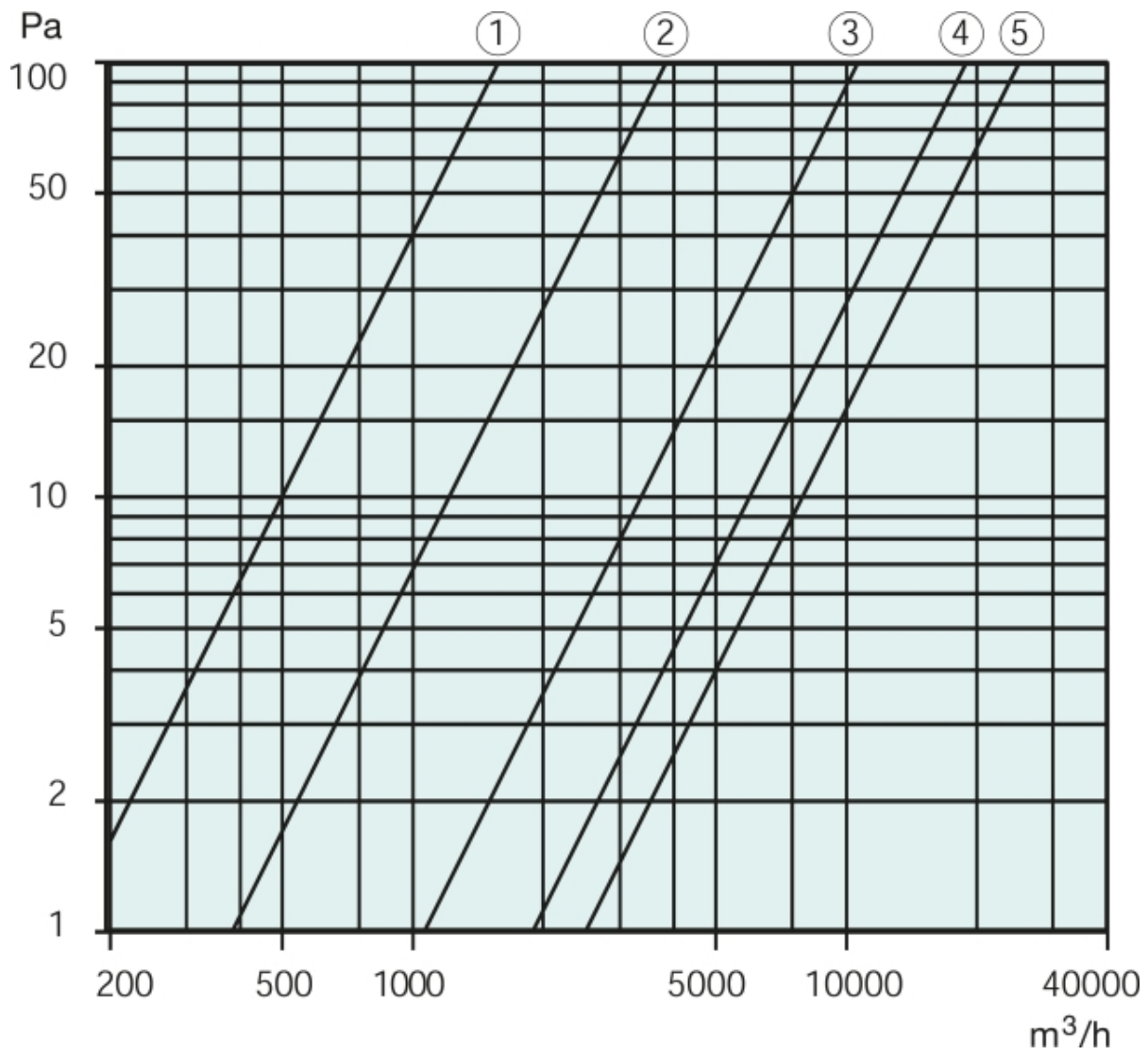

Pressure drop diagram

# Wiring

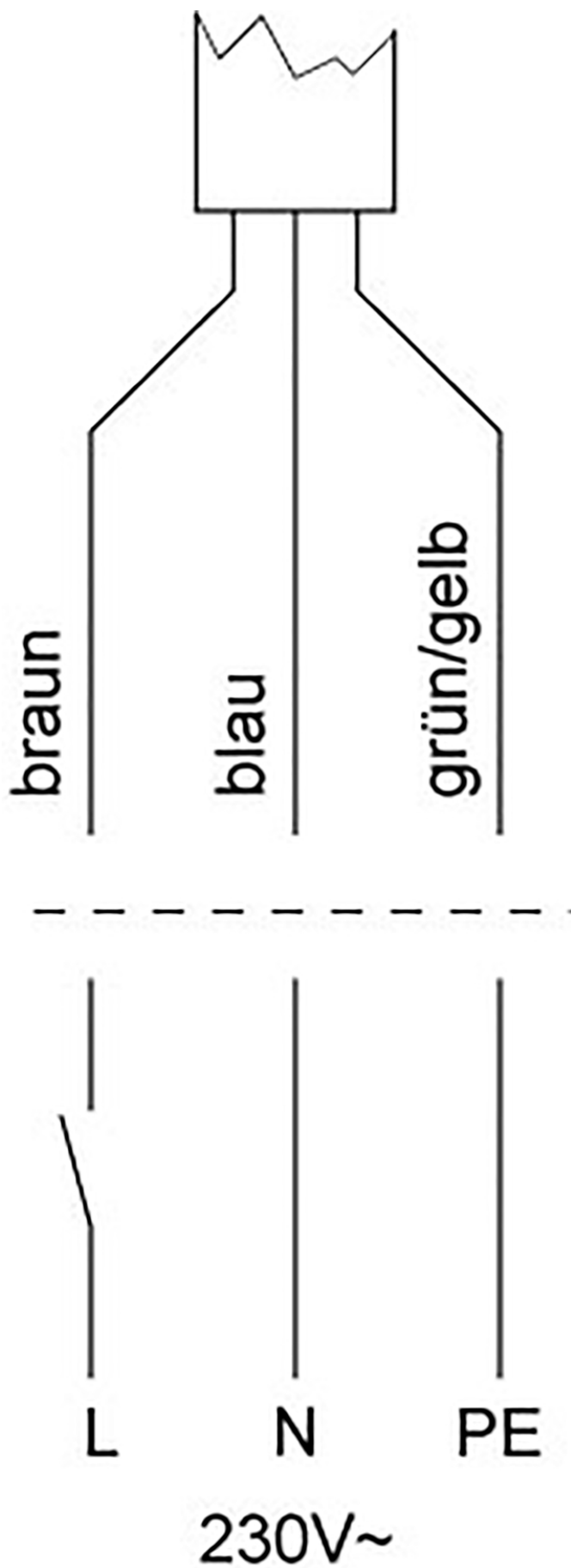

Colours

---

braun = brown

blau = blue

grün/gelb = green/yellow