

VKS-EX 355-500 BACK DRAFT DA.

Item no. 8484

Document type: **Product card**
Document date: **2019-05-14**
Generated by: **Systemair Online Catalogue**

Description

Automatic shutter

The automatic shutter VKS-EX consists of flanges manufactured from galvanized steel epoxy painted RAL 9005, and of shutter blades manufactured from painted galvanized steel RAL 9005.

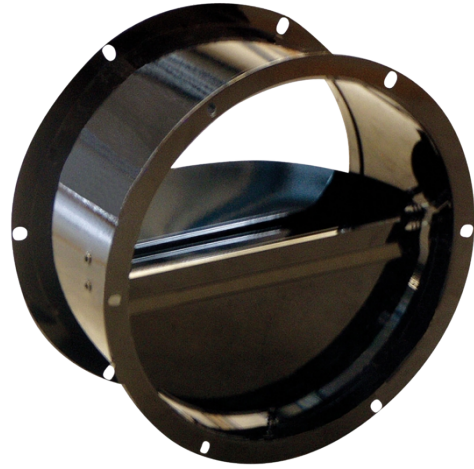

Technical parameters

Other	
Weight	4,8 kg

Dimensions

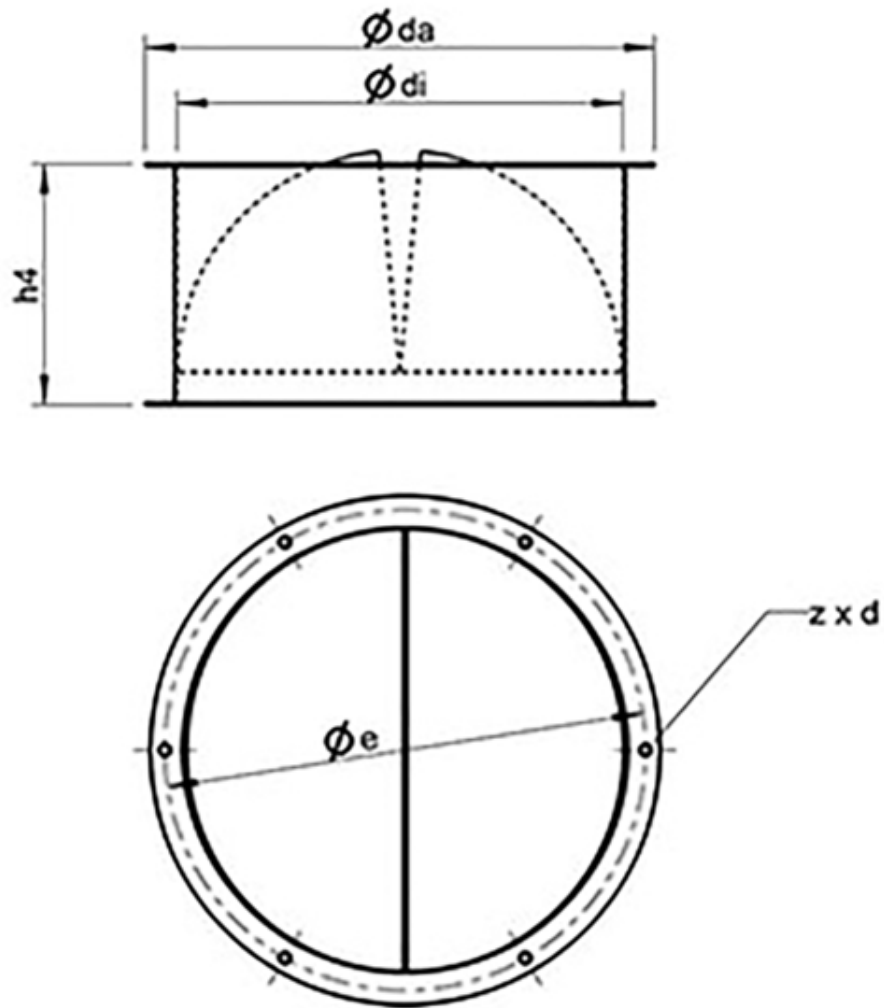

	$\varnothing da$	$\varnothing e$	$\varnothing di$	$h4$	$z \times d$
VKS-EX 315	306	285	256	156	6 x $\varnothing 7$
VKS-EX 355-500	464	438	402	220	6 x $\varnothing 9$
VKS-EX 560/630	639	605	569	255	8 x $\varnothing 9$

Documentation

 [VKS-EX-EC-Declaraton of conformity.pdf](#) (84,22kB)

 [Company statement_ATEX_Acce_.eng.pdf](#) (90,44kB)

Diagram

Pressure drop diagram

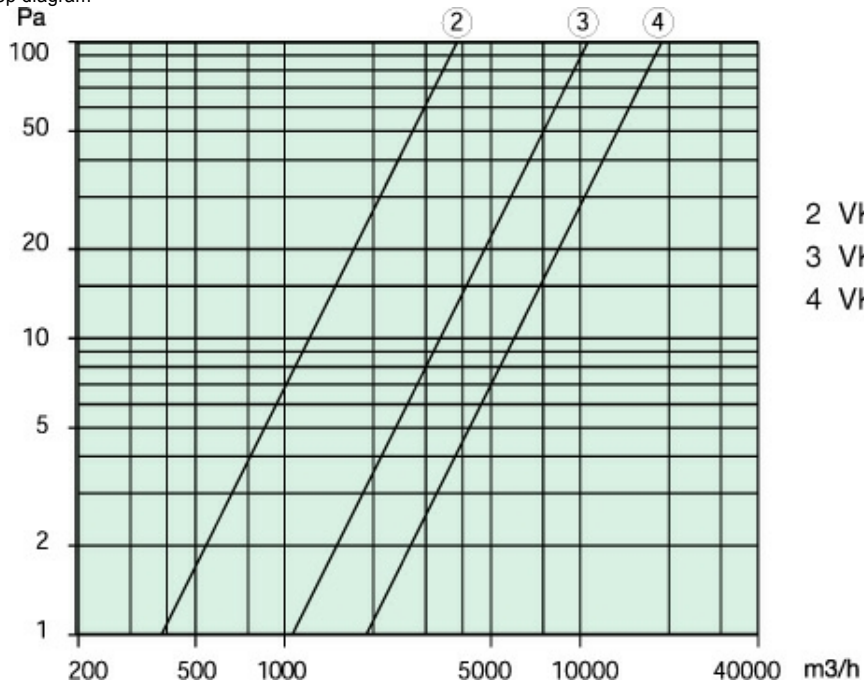

- 2 VKS-EX 310/311
- 3 VKS-EX 355-500
- 4 VKS-EX 560/630